

MODEL SELECTION TABLE

MODEL	MAX. VOLTAGE	MAX. CURRENT	MAX. POWER
XRBD160PN100	160kV	1mA	100 watts
XRBD160PN210	160kV	2.1mA	210 watts
XRBD160PN350	160kV	3.5mA	350 watts
XRBD160PN500	160kV	4mA	500 watts

LED INDICATORS

INDICATOR	SIGNAL	CONDITION Illuminated When...	LED COLOR
1	OV Error 6	High kV occurs	Red
2	UV Error 5	Low kV occurs	Red
3	UC Error 4	Low mA occurs	Red
4	OC Error 3	High mA occurs	Red
5	ARC Error 2	Arc fault occurs	Red
6	OT Error 1	Over temperature occurs	Red
7	X-Ray On	X-Rays are being generated	Green
8	Power On	AC input power is present	Green

SMART XRB

XRBD	620	20ms	62	620
	kV	kV		
	kV	mA		
HV		HV		
kV		mA		

RS-232
 O 9Vdc
 X
 kV mA
 X
 +40
 -40 +70
 10% 95%
 X
 100W /
 210W
 350/500W
 24Vdc @2A
 55
 24Vdc @5A
 M5
 M5
 X
 100/210W: 35.4kg
 350/500W: 38.3kg
 100W/210W: 1.18kg
 350W/500W: 3.18kg
 X
 5cm 0.5mR / hr
 EECEMC
 UL / CUL
 EEC
 E235530

Power and Interface Connections

AC INPUT—3 PIN PHOENIX CONTACT 1858772

PIN	SIGNAL	PARAMETERS
1	AC Input (high)	100-240Vac (high)
2	Ground	Ground
3	AC Input (neutral)	100-240Vac (neutral)

DC INPUT FOR HEAT DISSIPATION UNIT—4 PIN AMP (210/350/500W) 206060-1

PIN	SIGNAL	DESCRIPTION	PARAMETERS
1	24Vdc	Fan/Pump Power	24Vdc @ 5 amps
2	24Vdc Return		
3	N/C	No Connection	N/C
4	N/C	No Connection	N/C

It is critical to ensure that 24Vdc is supplied to pins 1 and 2

ANALOG INTERFACE—10 PIN PHOENIX CONTACT 1792605

PIN	SIGNAL	PARAMETERS
1	X-Ray Interlock Enable	Apply +24Vdc to enable interlock. Open/removal of +24Vdc will cause X-Ray generation to stop.
2	X-Ray Interlock Enable Return	Ground reference for X-Ray Interlock.
3	Pin removed	N/C
4	kV Monitor	0-10Vdc = 0-100% rated output voltage. Zout = 10kΩ
5	Signal Ground	Signal Ground
6	mA Monitor	0-10Vdc = 0-100% rated output current. Zout = 10kΩ
7	Fault Signal	Open collector, High (Open) = No Fault, 35Vdc @ 10mA maximum
8	HV ON Lamp Relay N/O	N/O dry contacts. 50 volts maximum. Rated for 1 amp or less, 50mA nominal load
9	HV ON Lamp Relay C	Common dry contacts. 50 volts maximum. Rated for 1 amp or less, 50mA nominal load
10	HV ON Lamp Relay N/C	N/C dry contacts. 50 volts maximum. Rated for 1 amp or less, 50mA nominal load

RS-232 DIGITAL INTERFACE—9 PIN MALE D CONNECTOR

PIN	SIGNAL	PARAMETERS
1	N/C	N/C
2	Transmitted Data	Conforms to EIA RS-232-C
3	Received Data	Conforms to EIA RS-232-C
4	N/C	N/C
5	Signal Ground	Signal Ground
6	N/C	N/C
7	N/C	N/C
8	N/C	N/C
9	N/C	N/C

ETHERNET DIGITAL INTERFACE—RJ45 8 PIN FEMALE CONNECTOR

PIN	SIGNAL	PARAMETERS
1	TX +	Transmit Data +
2	TX -	Transmit Data -
3	RX +	Receive Data +
4	N/C	No Connection
5	N/C	No Connection
6	RX -	Receive Data -
7	N/C	No Connection
8	N/C	No Connection

DIMENSIONS: in.[mm]

100/210W CONTROL UNIT

FRONT VIEW

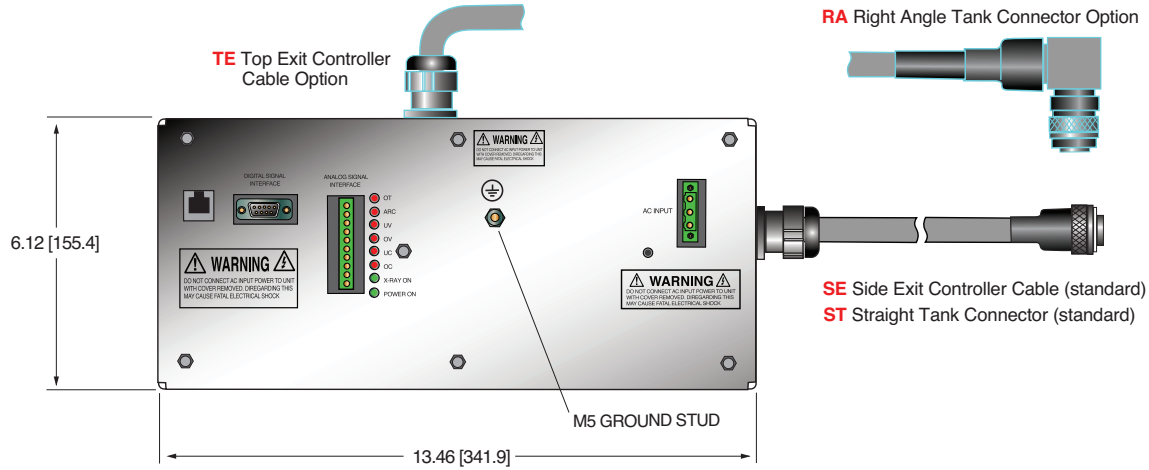

BOTTOM VIEW

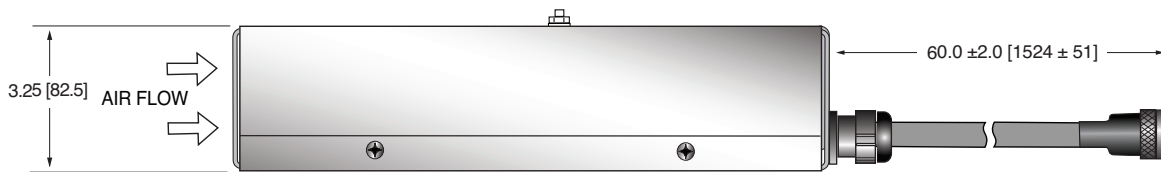

REAR VIEW

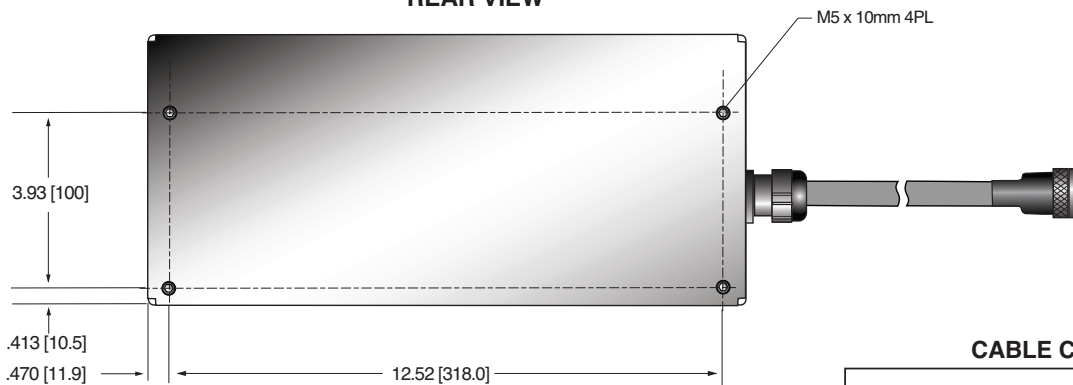

SIDE VIEW



SIDE VIEW

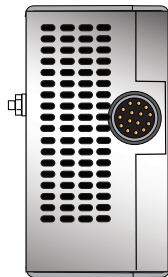

Standard
SE Side Exit
shown

CABLE CONFIGURATIONS

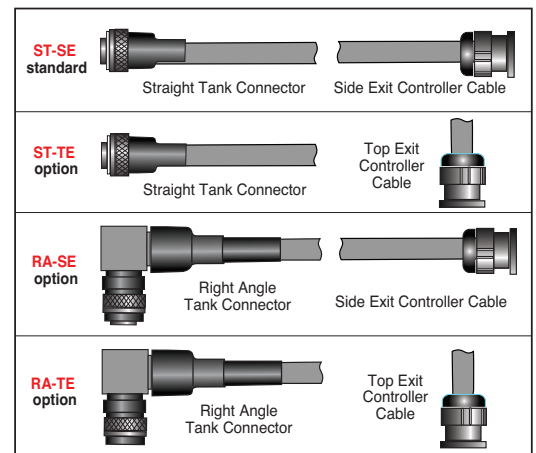

DIMENSIONS: in.[mm]

350/500W CONTROL UNIT

FRONT VIEW

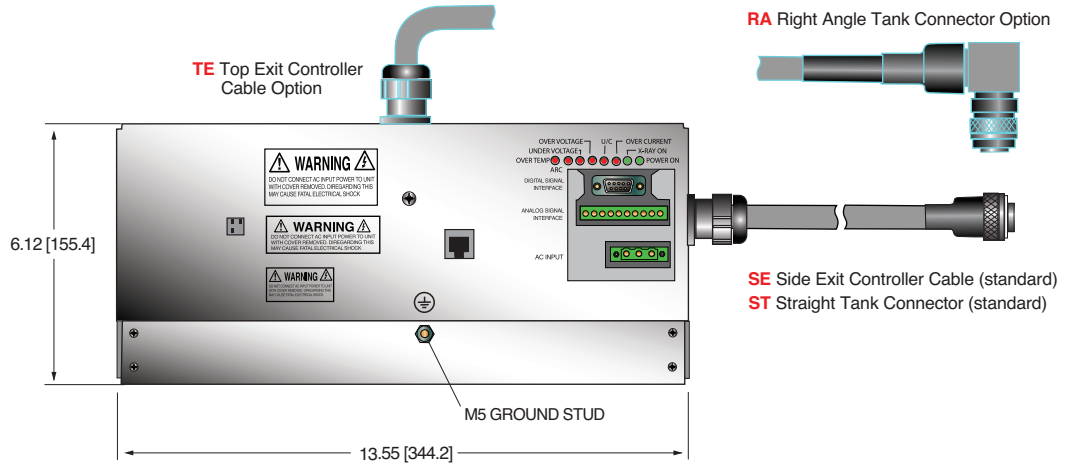

BOTTOM VIEW

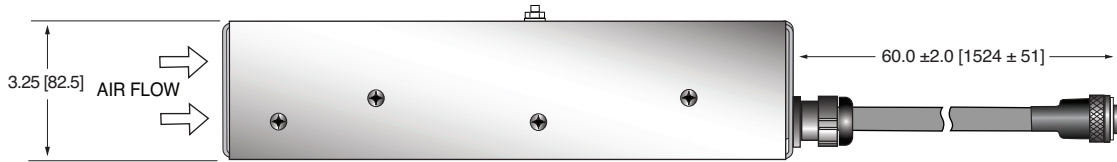

REAR VIEW

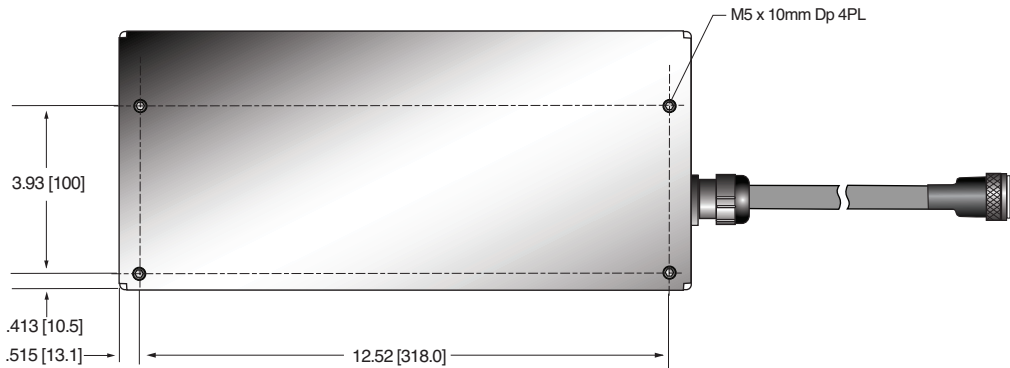

SIDE VIEW

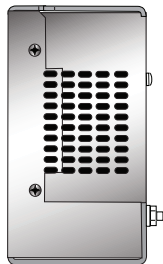

SIDE VIEW

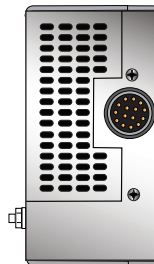

Standard
SE Side Exit
shown

DIMENSIONS: in.[mm]

100W TANK TOP VIEW

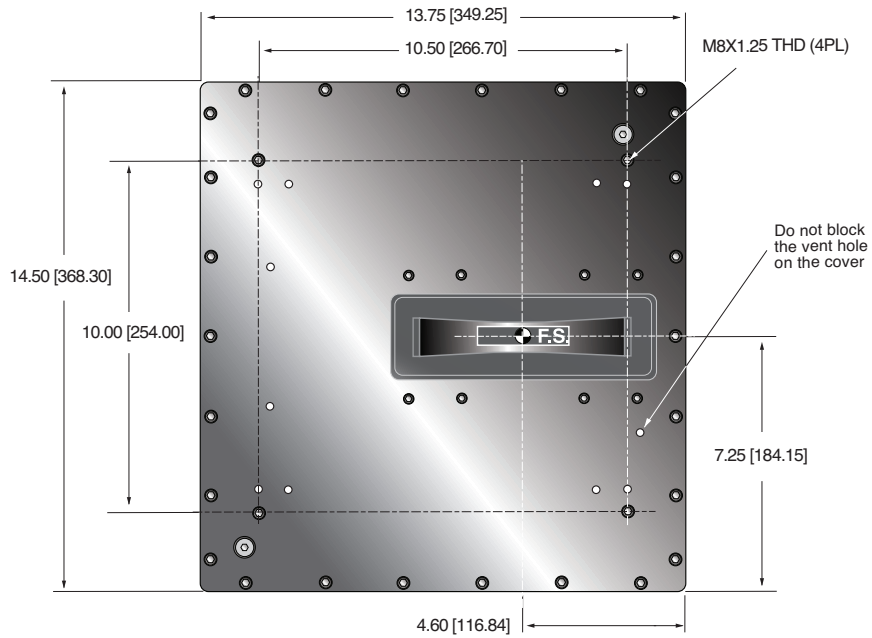

SIDE VIEW

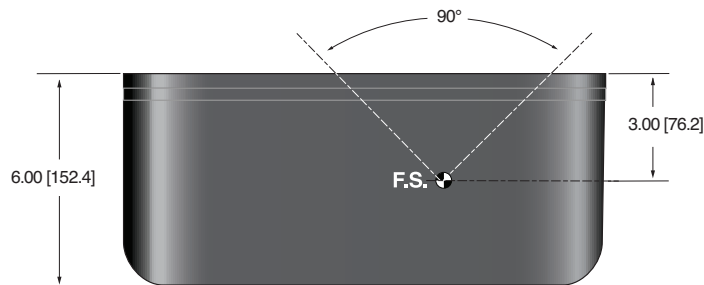

BACK VIEW

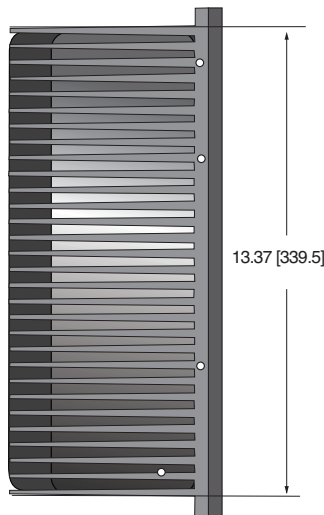

FRONT VIEW

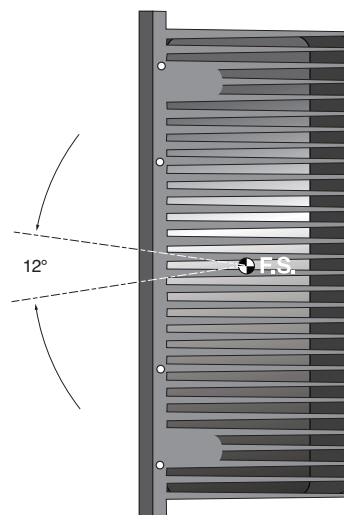

DIMENSIONS: in.[mm]

210W TANK TOP VIEW

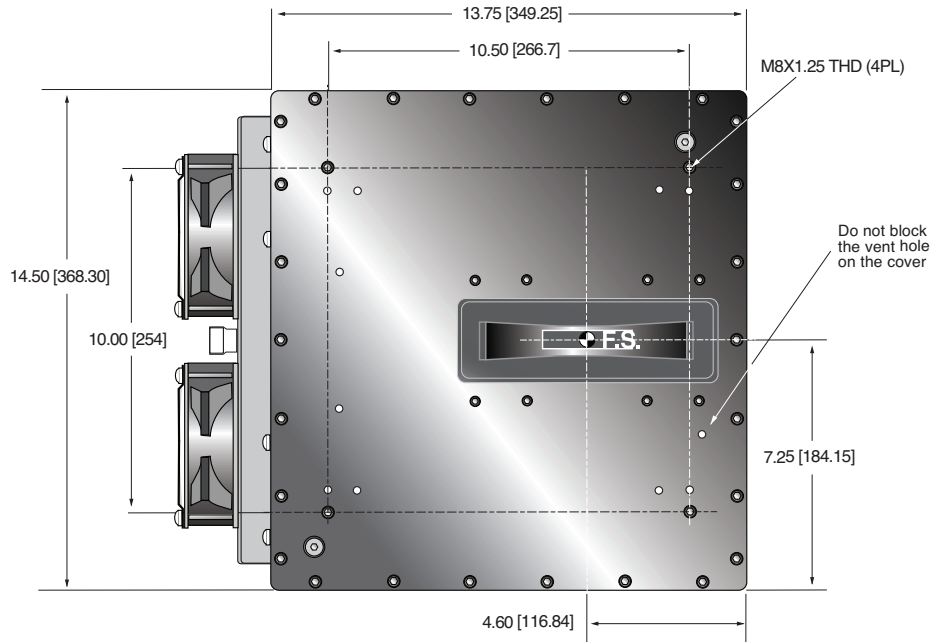

SIDE VIEW

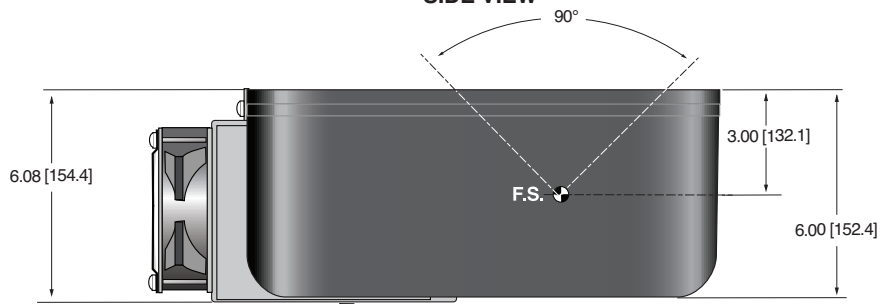

BACK VIEW

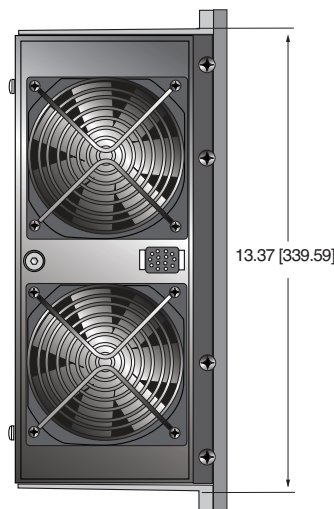

FRONT VIEW

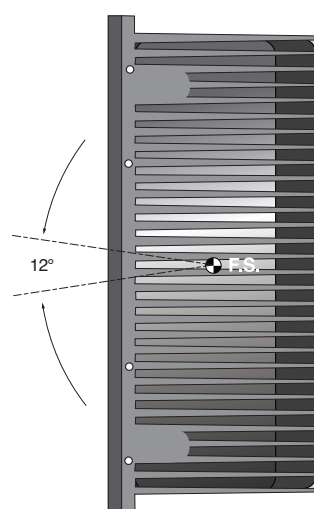

DIMENSIONS: in.[mm]

350/500W TANK

TOP VIEW

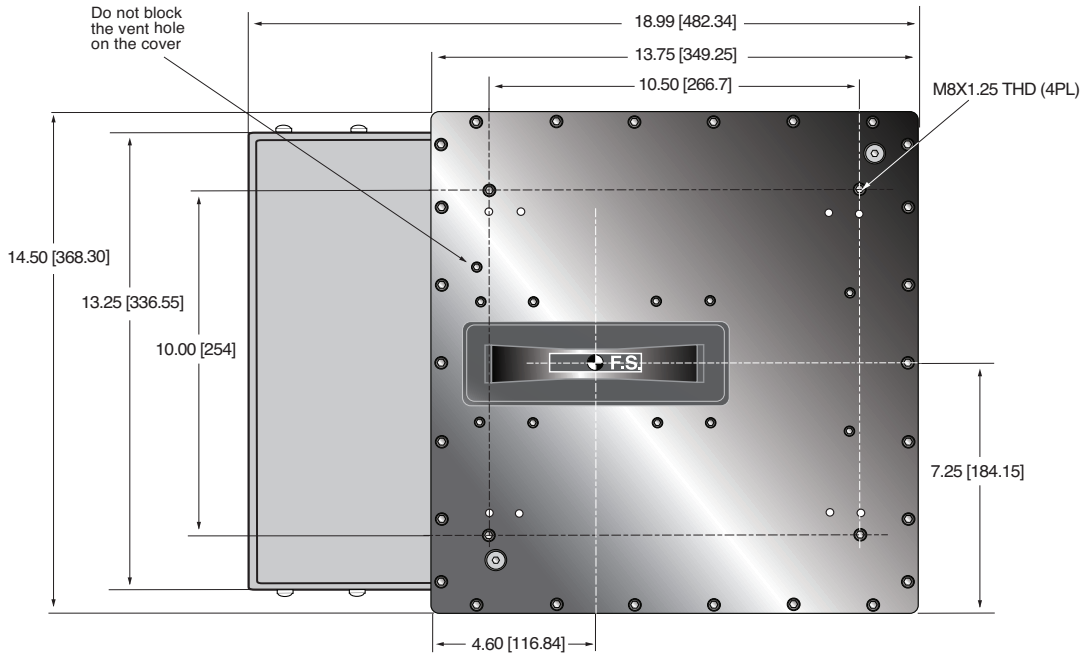

SIDE VIEW

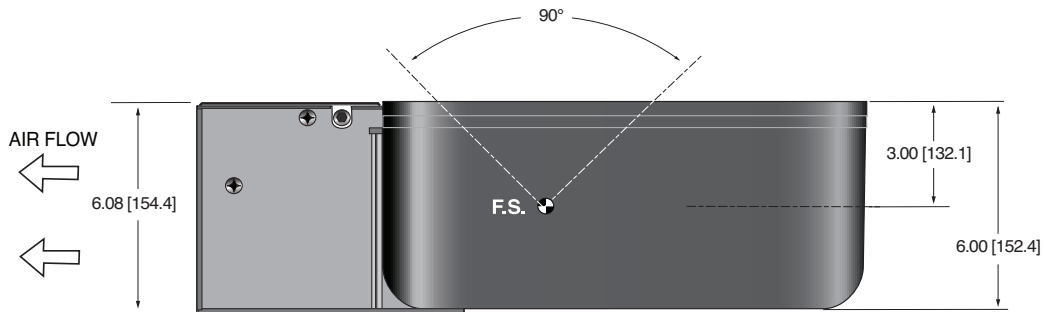

BACK VIEW

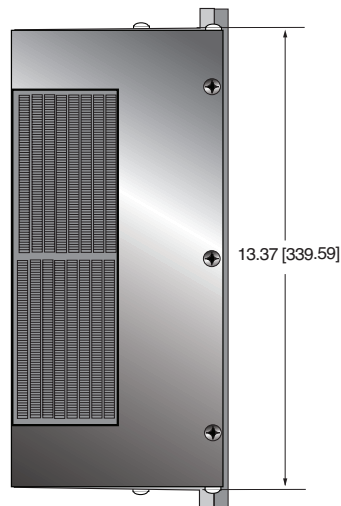

FRONT VIEW

