

Product:

MCP3P1/I15

Title:

Installation and User Guide



Document Number:

80366-4

Issue:

A

Date:

12/January/2022

Change History

| ISSUE | DATE | NAME | SECTION | CHANGE |
|-------|----------|------|---------|----------------------|
| A | Jan/2022 | MP | All | Created from 80366-1 |
| | | | | |
| | | | | |
| | | | | |
| | | | | |
| | | | | |

Contents

| | | |
|-------|--|---|
| 1. | Unit Description..... | 5 |
| 1.1 | Unit Ratings | 5 |
| 1.1.1 | Power Input..... | 5 |
| 1.1.2 | HV Output..... | 5 |
| 1.1.3 | Protection..... | 5 |
| 1.2 | Environmental conditions..... | 5 |
| 2. | Safety | 6 |
| 2.1 | Meaning of Symbols | 6 |
| 2.2 | Unit Grounding..... | 6 |
| 3. | Installing the Unit..... | 7 |
| 3.1 | Electrical Installation | 7 |
| 3.2 | Connections | 7 |
| 3.2.1 | Power input and signal connection..... | 7 |
| 3.2.2 | HV Outputs | 7 |
| 3.3 | Mechanical Installation | 8 |
| 4. | Operating the Unit..... | 8 |
| 4.1 | Voltage Programming | 8 |
| 4.2 | Voltage Monitor..... | 8 |
| | Appendix A - Mechanical layout | 9 |

SAFETY

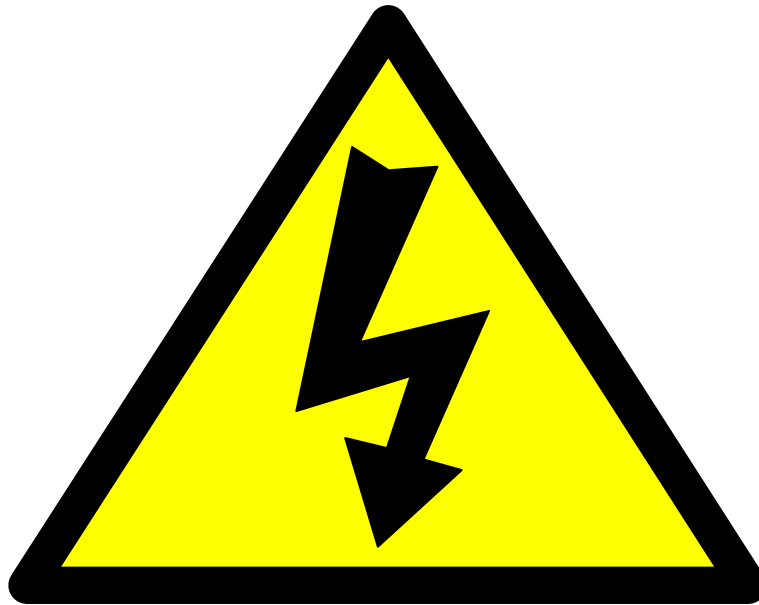

DANGER HIGH VOLTAGE RISK OF ELECTROCUTION

Observe extreme caution when working with this equipment

- High voltage power supplies must always be connected to protective earth
- Do not touch connections unless equipment is turned off and the capacitance of both the load and power supply are grounded
- Allow adequate time for discharge of internal capacitance of the power supply
- Do not ground yourself or work under wet or damp conditions

Servicing Safety

- Maintenance may require removing the Instrument cover with the power on
- Servicing should only be done by qualified personnel aware of the hazards
- Return to supplier for servicing

| | | |
|--|--------------------------|----------|
| MCP3P1/I15 Installation and User Guide | Document Number: 80366-4 | Issue: A |
| Spellman High Voltage Electronics Limited +44 (0)1798 877000 hvsales@spellmanhv.co.uk Broomers Park, Pulborough, W. Sussex, UK. RH20 2RY | | |

SÉCURITÉ

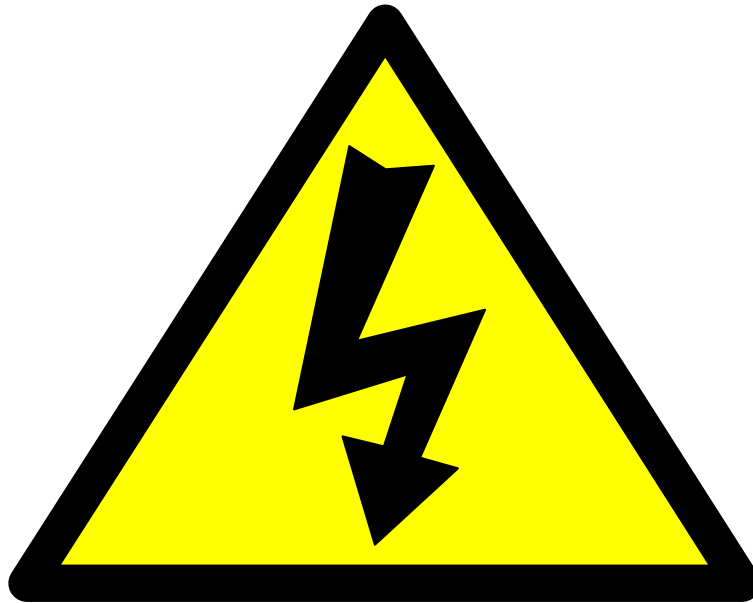

DANGER HAUTE TENSION RISQUE D'ÉLECTROCUTION

Observez une extrême prudence lorsque vous travaillez avec cet équipement

- Les alimentations haute tension doivent toujours être connectées au conducteur de protection.
- Ne pas toucher les connexions à moins que l'équipement soit éteint et que la capacité de la charge et de l'alimentation électrique ne soit mise à la terre.
- Prévoir un temps suffisant pour la décharge de la capacité interne de l'alimentation.
- Ne pas vous mettre à la terre ou travailler dans des conditions humides.

Sécurité d'entretien

- L'entretien ne doit être effectué que par un personnel qualifié et conscient des dangers.
- Il n'y a pas de pièce remplaçables par l'utilisateur dans l'unité, retourner au fournisseur pour l'entretien.

1. Unit Description

The MCP3P1/I15 HV unit is a 3kV, 330uA, DC to DC converter, it is packaged in a shielded metal enclosure. The output is isolated from ground to 15kV, such that it can be floated upon the HV output of an accelerator voltage or other high voltage source, as shown in the diagram below.

The unit has remote voltage programming and a voltage monitor, it features low injected ripple when used with biasing supplies. Typical applications for the unit are:

- Mass Spectrometry Detectors
- Microchannel Plates
- Electron Multipliers
- Channel Electron Multipliers

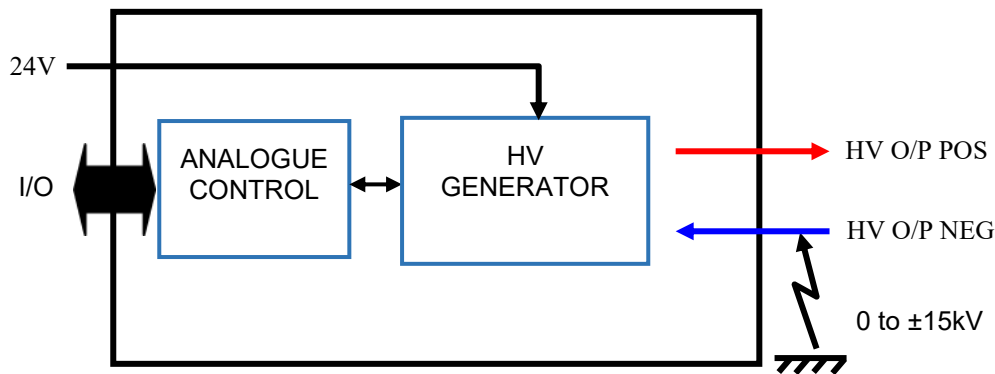

1.1 Unit Ratings

1.1.1 Power Input

24Vdc \pm 10%, 600mA (max)

1.1.2 HV Output

100Vdc to 3kVdc. 330 μ A (max)

1.1.3 Protection

Isolation provided for 15kV (to float on an external supply)

1.2 Environmental conditions

Temperature Range:

Operating: 0°C to +40°C



Storage: -35°C to +85°C

| | | |
|--|--------------------------|----------|
| MCP3P1/I15 Installation and User Guide | Document Number: 80366-4 | Issue: A |
| Spellman High Voltage Electronics Limited +44 (0)1798 877000 hvsales@spellmanhv.co.uk Broomers Park, Pulborough, W. Sussex, UK. RH20 2RY | | |

2. Safety

The conditions of this manual must be complied with to maintain safety; operating the unit in a manner not defined in this manual may compromise the protection from electric shock.

2.1 Meaning of Symbols

| SYMBOL | MEANING |
|---|--|
|  | Refer to manual before operating |
|  | Caution, possibility of electric shock |
|  | Protective conductor terminal (PE) |

2.2 Unit Grounding

The unit is contained in an earthed case. The case of the unit shall be properly bonded, via the unit chassis, to the main protective earth termination in the end product.

3. Installing the Unit

3.1 Electrical Installation

The unit is designed for indoor use and is to be supplied from a double insulated, UL recognised, 24V dc supply.

- 1) The unit shall be properly bonded to the main protective earthing termination in the end product.
- 2) The unit should only be used in a Pollution Degree 2 Installation Category II environment.
- 3) Consideration should be given to conduct the following tests with the power supply installed in the end product:
 - Dielectric withstand test, between live parts of the power supply and the end product chassis.
 - Permissible Limits Test with the power supply installed in the end product.
- 4) The input and output connectors are not intended for field connections and should only be connected to internal wiring in the end use equipment.
- 5) The unit is intended for use as a component and no surface of the unit should be accessible in the end product.
- 6) The unit is contained in an enclosed case and can be mounted in any orientation. A cooling air flow is recommended.

3.2 Connections

3.2.1 Power input and signal connection

Signal I/O is provided through a standard 9 way 'D' type male connector mounted in the end of the unit (see mechanical outline). The pin connections used are shown in the table below.

| pin# | Signal | I/O | Description | Remarks |
|------|---------------|-----|--|---------|
| 1 | Signal Gnd | - | Signal ground | |
| 2 | V control | I | Voltage Control input. 0 to +10Vdc for to 0 to 3kV. Accuracy $\pm 1\%$. | See 4.1 |
| 3 | +24VDC | I | Power input. It is recommended to connect both pins. | |
| 4 | +24VDC | I | | |
| 5 | V monitor | O | Output voltage monitor. 0 to +5Vdc for 0 to 3kV. Accuracy $\pm 10\%$. | See 4.2 |
| 6 | +24VDC Return | I | Ground return for DC in. For best performance it is recommended to connect all pins. | |
| 7 | +24VDC Return | I | | |
| 8 | +24VDC Return | I | | |
| 9 | +24VDC Return | I | | |

3.2.2 HV Outputs

The standard HV output leads are as follows.

HV positive: 1000mm flying lead un-terminated URM76

HV negative: 1000mm flying lead un-terminated URM76

3.3 Mechanical Installation

The unit shall be fixed in place in the end user system using screws on the hold down points provided.

Unit weight: 1kg

Mechanical Dimensions - see drawing in Appendix A

4. Operating the Unit

4.1 Voltage Programming

The output voltage of the module is controlled by a 0 to +10Vdc input corresponding to 0 to 3kV on the HV O/P POS with respect to the HV O/P NEG. At control voltages above 1v the output will reflect the control voltage to an accuracy of $\pm 1\%$. At control voltages of less than 1v the output voltage will be proportional to the control voltage.

4.2 Voltage Monitor

The voltage monitor output signal is 0 to +5Vdc, which represents 0 to 3kV $\pm 10\%$

| | | |
|--|--------------------------|----------|
| MCP3P1/I15 Installation and User Guide | Document Number: 80366-4 | Issue: A |
| Spellman High Voltage Electronics Limited +44 (0)1798 877000 hvsales@spellmanhv.co.uk Broomers Park, Pulborough, W. Sussex, UK. RH20 2RY | | |

Appendix A - Mechanical layout

