

- **Integrated HV Supply, Filament Supply, X-Ray Tube, Beam Port and Control Electronics**
- **Compact & Lightweight**
- **Universal Input, Power Factor Corrected with Internal EMI Filter**
- **Can be Mounted in Any Physical Orientation**
- **Analog Monitoring Interface and Standard RS-232 Digital Program and Monitor Interface**
- **Data Logging and Firmware Controlled X-Ray Tube Seasoning (Smart Controller Option Only)**

www.spellmanhv.com/manuals/XRB80PN100HR

Spellman's XRB80PN100HR (high reliability) Monoblock® X-Ray source is designed for OEM applications powering its internal Bipolar X-Ray tube up to 80kV at 100W.

Features like universal input, small package size and a standard RS-232 digital interface simplify integrating this Monoblock® into your X-Ray system. The XRB80PN100HR is available either with fan shaped (standard) or (optional) cone shaped beam geometries. Proprietary emission control circuitry provides excellent regulation of X-Ray tube current, along with outstanding stability performance. The XRB80PN100HR is designed for long field life and comes with a 3 year warranty.

TYPICAL APPLICATIONS

X-Ray Scanning, Thickness Measurement, Food Inspection, Fill Level Confirmation, Parcel Inspection

OPTIONS

CB	Cone Beam
.5mm	.5mm focal spot X-Ray tube
NF	80° x 10° Narrow Fan beam
RA	Right Angle cable
SC	Smart Controller

SPECIFICATIONS

X-Ray Characteristics:

Focal Spot: 0.8mm (IEC 336) standard
0.5mm (IEC 336) optional

Beam Filter:

Ultem: 3.00mm ±0.15mm
Oil: 7.5mm ±0.25mm
Glass: 1.7mm ±0.2mm
Be: 0.8mm

Beam Geometry:

Fan: The standard beam angular coverage will be 80° with the beam plane perpendicular to the X-Ray tube axis and 20° wide (with a 2° tolerance)
An optional 80° x 10° (with a 2° tolerance) is also available

Cone: Optional. 20° cone beam (with a 2° tolerance)

Input Voltage:

Power factor corrected input 0.98, 100-240Vac ±10%
50/60Hz, 2A maximum

X-Ray Tube Voltage:

Nominal X-Ray tube voltage is adjustable 40kV (±20kV)
to 80kV (±40kV)

X-Ray Tube Current:

150uA to 2.00mA over specified tube voltage range
(100W max.)

X-Ray Tube Power:

100W maximum continuous

Voltage Regulation:

Line: ±0.05% of maximum output voltage over a ±10%
change of nominal input line voltage

Load: ±0.1% of maximum rated voltage for 150uA
to 2.00mA load change

Voltage Accuracy:

Voltage measured across the X-Ray tube is within
±2% of the programmed value

Voltage Risetime:

Ramp time shall be <500ms from 10% to
90% of maximum rated output voltage

Voltage Ripple:

0.5% peak to peak of maximum voltage for frequencies ≤1kHz

Emission Current Parameters

Current Regulation:

Line: ±0.05% of rated output current over a
±10% change of nominal input line voltage

Load: ±0.1% of rated output current for a change
from 50% to 100% of rated output voltage

Current Accuracy:

Current measured through the X-Ray tube is within
±2% of the programmed value

Current Risetime:

Ramp time shall be <500ms from 10% to 90%
of maximum rated current

Arc Intervention:

4 arcs in 10 seconds with a 100ms quench/100ms
re-ramp = Shutdown

Filament Configuration:

Internal AC filament drive with closed loop filament emission control

Analog Monitoring Interface:

Ground referenced 0 to 9Vdc for all monitoring signals. Relay contacts and open collector signals for other signals. See analog interface connector pin out table.

Digital Programming and Monitoring Interface:

The RS-232 interface allows for programming of kV, mA output and X-Ray enable. Provides monitoring for kV, mA output and oil temperature. Tolerance 3%. (with an additional 5µA offset at ≤10% mA programming)

Control Software:

A demo GUI is available for engineering evaluations

Operating Temperature:

0°C to +40°C

Storage Temperature:

-40°C to +70°C

Humidity:

10% to 95% relative humidity, non-condensing

Cooling:

X-Ray Tank: Customer provided 250 cfm external cooling fan as required to maintain oil temperature below 55°C.

Controller: Forced air via internal fan.

Input Line Connector:

3-pin Phoenix Contact 1829167. Mating connector provided with unit

Analog Interface Connector:

15 pin male D connector provided with unit

Digital Interface Connector:

9 pin female D connector provided with unit

Grounding Point:

M4 ground stud provided on chassis

Dimensions:

X-Ray Tank: 11.3”L x 9.625”W x 4.93”H
(287.02mm x 244.4mm x 125.2mm)

Standard
Controller: 8.5”L x 6.70”W x 2.21”H
(215.9mm x 170.2mm x 56.1mm)

Smart
Controller: 8.5”L x 7.14”W x 2.40”H
(215.9mm x 181.4mm x 61.0mm)

Weight:

X-Ray Tank: 36lbs (16.32kg)

Standard
Controller: 3.7lbs (1.68kg)

Smart
Controller: 3.9lbs (1.77kg)

Orientation:

Can be mounted in any orientation.

X-Ray Leakage:

Not to be greater than 0.5mR/hr at 5cm outside the external surface.

Regulatory Approvals:

Compliant to EEC EMC Directive. Compliant to EEC Low Voltage Directive. UL/CUL recognized file E235530

SMART XRB (only available with Smart Controller option)

The XRB80PN100HR with the Smart Controller (SC option) has two new digital features available: data logging and firmware controlled seasoning.

Data Logging:

Think of this as an "airplane black box". The data logging captures data on fault events and non-fault events. Fault events will turn off the high voltage:

FAULT EVENTS

Temperature	Arc
High Current	Low Voltage
High Voltage	Watchdog
Power Fault	Interlock

The XRB80PN100HR stores data 620ms before the event, the event itself and for 620ms after the event. Data is recorded every 20ms (62 samples total) showing:

Anode kV	Cathode kV
Total kV	Total mA
Filament	Temperature

We also log non-fault events, these are changes in set points or state of the unit.

NON FAULT EVENTS

HV On	HV Off
kV Set point	mA Set point
Low Current	Pre Heat Set point

Fault event data is actual graphical data. Non fault event data is just stored as event type, data and timestamp. We also have a preventative maintenance fault, which throws a non-shutdown alarm if the X-Ray tube has been factory installed over 4 years ago or if over 15,000 hours of HV ON is logged.

Firmware Controlled Seasoning:

Every unit comes with an initial seasoning table, or customers can set their own. The XRB80PN100HR knows when the unit has been on, when it has been off, hours on the X-Ray tube, etc. As a preventative maintenance feature upon turn on, we review the data and suggest that a particular seasoning protocol be run based upon the actual usage history of the unit. Proper seasoning compliance of the X-Ray tube will help get the longest lifetime.

How to Order:

Standard	PART NO.: XRB80PN100HR
Cone Beam Option	PART NO.: XRB80PN100HR/CB
0.5mm Focal Spot Option	PART NO.: XRB80PN100HR/.5mm
Narrow Fan Beam Option	PART NO.: XRB80PN100HR/NF
Cable Option	PART NO.: XRB80PN100HR/RA
Smart Controller Option	PART NO.: XRB80PN100HR/SC

AC LINE POWER CONNECTOR — J1 THREE POSITION PHOENIX CONTACT

PIN	SIGNAL
1	Earth Ground
2	Line
3	Neutral

Mating connector provided with unit

XRB80PN100HR ANALOG INTERFACE — J2 15 PIN MALE D CONNECTOR

PIN	SIGNAL	PARAMETERS
1	Power Supply Fault Output	Open collector, 35V @ 10mA max. high = no fault
2	N/C	No Connection
3	N/C	No Connection
4	X-Ray On Lamp Relay Output	Common, dry contacts, 30Vdc @ 1A, max
5	X-Ray On Lamp Relay Output	Normally open, X-Ray ON = closed
6	mA Monitor Output	0 to 9Vdc = 0 to 100% rated output, Zout = 10kΩ
7	X-Ray On Lamp Relay Output	Normally closed, X-Ray ON = open
8	kV Monitor Output	0 to 9.00Vdc = 0 to 100% rated output, Zout = 10kΩ
9	Signal Ground	Ground
10	Signal Ground	Ground
11	HV Interlock Return Input	Connect to Pin 12 to close HV interlock
12	HV Interlock Output	+15Vdc @ open, 5mA when connected to pin 11
13	X-Ray Enable Output	+15Vdc @ open, 5mA when connected to pin 15
14	X-Ray Status Output	Open collector, 35V @ 10mA max high = X-Ray OFF
15	X-Ray Enable Return Input	Connect to pin 13 to enable X-Ray generation (for local enable)

RS-232 DIGITAL INTERFACE — J3 9 PIN FEMALE D CONNECTOR

PIN	SIGNAL	PARAMETERS
1	N/C	No Connection
2	TD	Transmit Data
3	RD	Receive Data
4	N/C	No Connection
5	SGND	Signal Ground
6	N/C	No Connection
7	N/C	No Connection
8	N/C	No Connection
9	N/C	No Connection

ETHERNET DIGITAL INTERFACE* — J4 8 PIN RJ45 CONNECTOR

PIN	SIGNAL	PARAMETERS
1	TX+	Transmit Data +
2	TX-	Transmit Data -
3	RX+	Receive Data +
4	N/C	No Connection
5	N/C	No Connection
6	RX-	Receive Data -
7	N/C	No Connection
8	N/C	No Connection

*Ethernet interface for Smart Controller option only

LED INDICATORS

INDICATOR	SIGNAL NAME	CONDITION Illuminated When...
LED 1	OV	High kV occurs
LED 2	UV	Low kV occurs
LED 3	UC	Low mA occurs
LED 4	OC	High mA occurs
LED 5	ARC FLT	Arc fault occurs
LED 6	OT	Over temperature occurs
LED 7	X-RAY ON	X-Rays are enabled
LED 8	PWR	Power is ON

DIMENSIONS: in.[mm]

STANDARD CONTROL UNIT

TOP VIEW

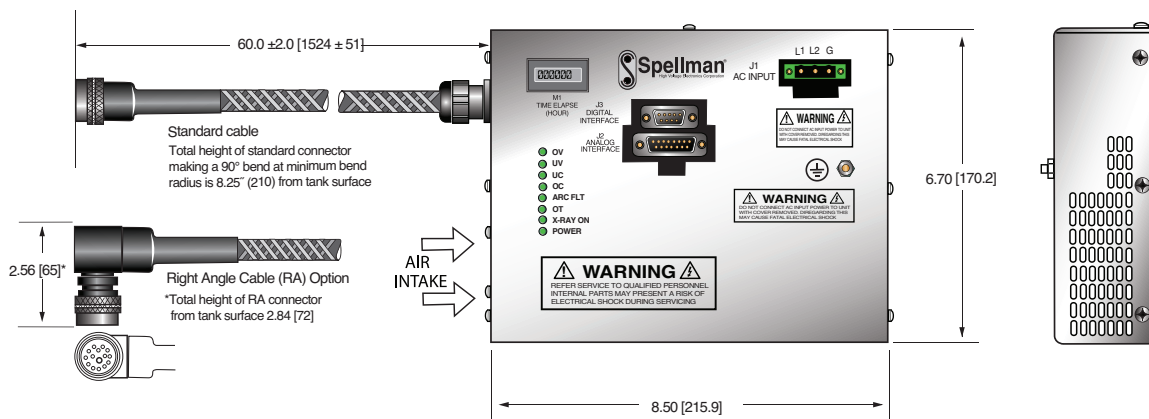

SIDE VIEW



BOTTOM VIEW

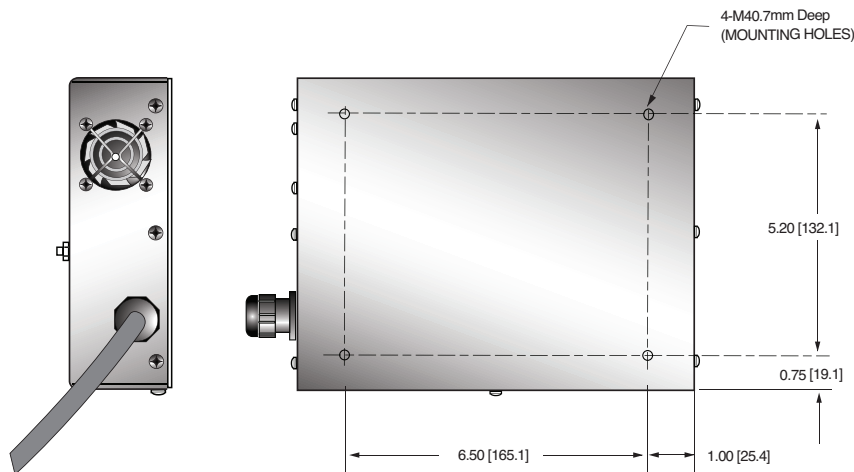

DIMENSIONS: in.[mm]

SMART CONTROL UNIT

TOP VIEW

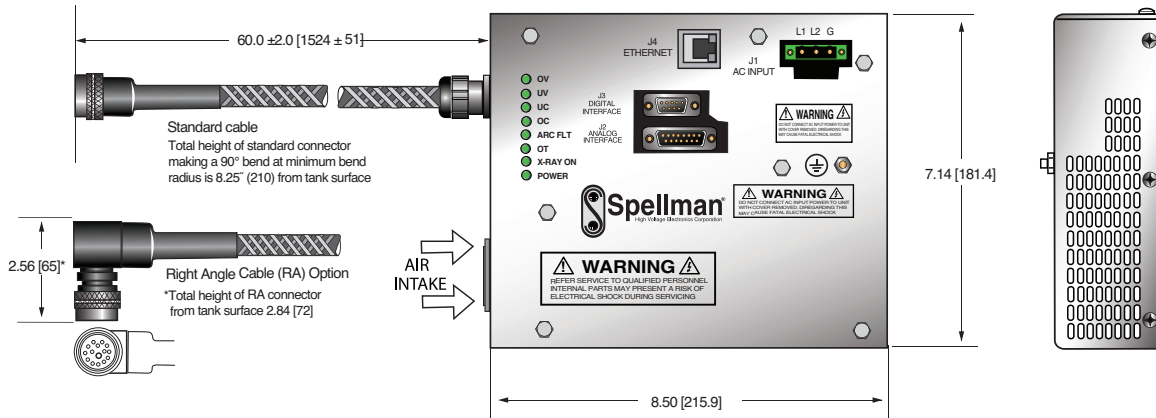

SIDE VIEW



BOTTOM VIEW

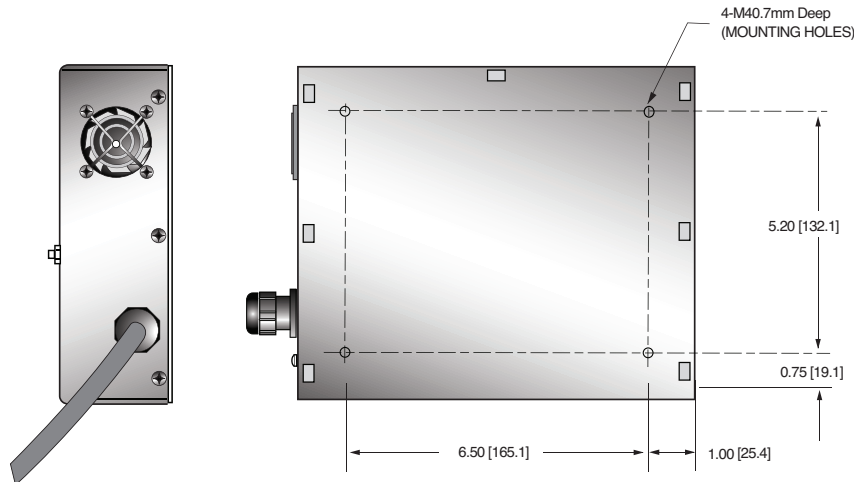

DIMENSIONS: in.[mm]

GENERATOR TANK TOP VIEW

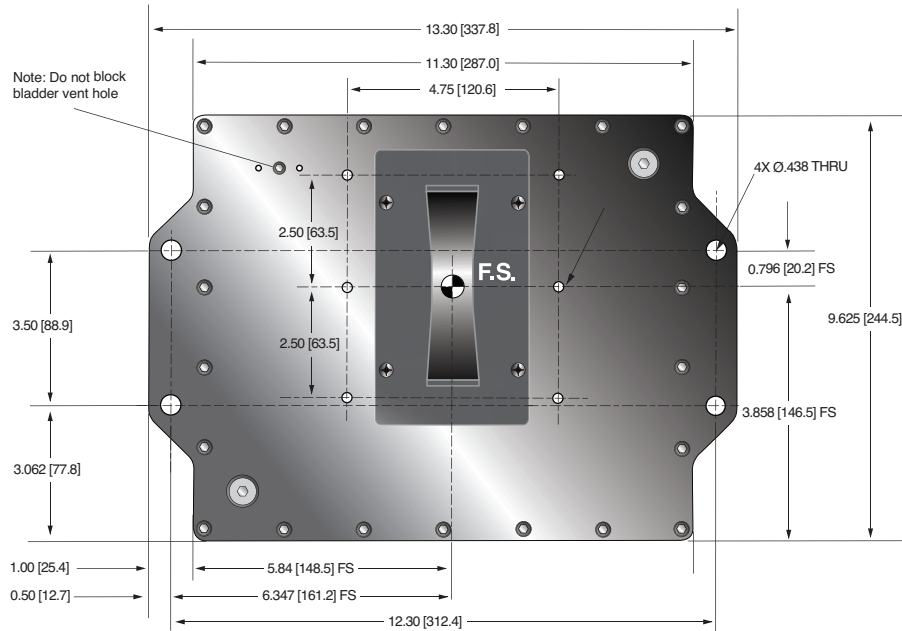

FRONT VIEW

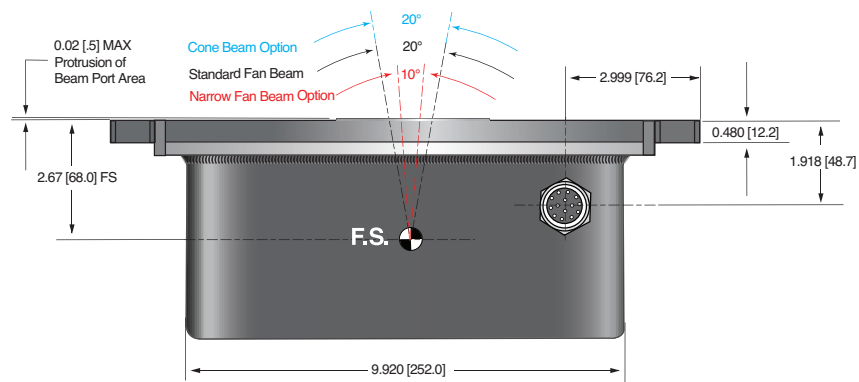

SIDE VIEW

