



12kW 10.50" (6U) Chassis



- **Specially Designed for E Beam Coating Applications**
- **3kW, 6kW and 12kW Power Levels**
- **Remote Analog and Ethernet/RS-232 Interface**
- **Arc and Short Circuit Protected, Fast Arc Recovery**
- **User Configurable Dynamic Arc Intervention**
- **Optional Filament Gun Supply (up to 3 channels)**
- **OEM Customization Available**

Spellman's new EVA Series is specifically designed for demanding electron beam coating applications. A full featured front panel provides local control, while an extensive analog interface allows remote capability. The included Ethernet and RS-232 digital interfaces simplify integrating the EVA into your system design.

The EVA's robust IGBT inverter design is inherently fault tolerant. The proprietary low capacitance, low stored energy high voltage output section is ideal for dynamic load and fault conditions encountered in coating applications. Fast arc recovery times (<2ms) minimize process interruptions. Many operational parameters can be configured by the user to suit their particular requirements via the provided graphical user interface (GUI).

An optional filament gun supply is available. The EVA can support one, two or three filament gun supply channels providing unprecedented flexibility and cost effectiveness.



3kW/6kW 5.25" (3U) Chassis

3/6/12KW HV SPECIFICATIONS

Input Voltage: (must be specified at time of order)

- Option 3PH: 180-264Vac, 50/60Hz, three phase, 90% efficiency, 0.85 power factor
- Option 1PH: 180-264Vac 50/60Hz, single phase, 90% efficiency, 0.65 power factor (3kW & 6kW only)
- Option 400VAC: 360-528Vac 50/60Hz, three phase, 90% efficiency, 0.85 power factor (6kW & 12kW only)

Input Current:

- Option 3PH: 180-264Vac, 50/60Hz, three phase
3kW—13 amps, maximum
6kW—25 amps, maximum
12kW—50 amps, maximum
- Option 1PH: 180-264Vac, 50/60Hz, single phase
3kW—29 amps, maximum
6kW—57 amps, maximum
- Option 400VAC: 360-528Vac, 50/60 Hz, three phase,
6kW—13 amps, maximum
12kW—25 amps, maximum

Output Voltage:

- 5kV @ 600mA, negative polarity. 3kW maximum.
- 10kV @ 600mA, negative polarity. 6kW maximum.
- 10kV @ 1200mA, negative polarity. 12kW maximum.

Local Output Controls:

Voltage is continuously adjustable over entire range via a 10 turn potentiometer.

Voltage Regulation:

- Load: 0.05% of full voltage +500mV for full load change.
- Line: 0.05% of full voltage +500mV over specified input range.

Ripple:

<3% Vrms

Stability:

0.02%hr. after 1 hour warm-up.

Temperature Coefficient:

100ppm/°C.

Environmental:

- Temperature Range:
 - Operating: 0°C to 40°C
 - Storage: -40°C to 85°C
- Humidity:
 - 10% to 90% RH, non-condensing.

Cooling:

Forced air; inlet through side panels, outlet at rear panel

Metering:

Front panel digital voltage and current meters, 3.5 digit, accurate to within 1%.

HARDWARE BASED OPTIONS

- 3PH** 180-264Vac Three Phase Input
- 1PH** 180-264Vac Single Phase Input (3kW & 6kW only)
- 400VAC** 360-528Vac, Three Phase Input (6kW & 12kW only)
- LL(X)** High Voltage Cable Length
- HV2** Two High Voltage Output Connectors
- HV3** Three High Voltage Output Connectors
- FIL1** Filament Gun Supply—One Channel
- FIL2** Filament Gun Supply—Two Channels
- FIL3** Filament Gun Supply—Three Channels
- HPF** 50 Amp Filament Supply

SOFTWARE CONFIGURABLE FEATURES

- Adjustable Overload Trip
- Arc Trip Count
- Arc Quench Time
- Arc Reramp Time
- Arc Window Time

3/6/12KW HV SPECIFICATIONS

System Status Display:

"Dead Front" type indicators provide status of up to 12 system parameters including voltage regulation, fault conditions and circuit control.

Input Power Connector:

A 6 foot (1.8 meter) long captive line cord will be provided.

Analog Interface Connector:

50 pin female D connector

High Voltage Output Cable:

10 ft (3.05m) shielded high voltage cable, removable at rear panel.

Dimensions:

3kW/6kW Units:

5.25"(3U)H x 19" W x 21" D (133mm x 482mm x 533mm)

12kW Units:

10.5"(6U)H x 19" W x 21" D (266mm x 482mm x 533mm)

Weight:

3kW/6kW Units: 46 pounds (20.87kg)

12kW Units: 90 pounds (40.82kg)

Regulatory Approvals:

Compliant to EEC EMC Directive. Compliant to EEC Low Voltage Directive. UL/CUL recognized file E227588. RoHS compliant.

Digital Interface

The EVA features a standard RS-232 and Ethernet digital interface, simplifying power supply communication requirements saving the user time and money, while enhancing functionality and overall capability. Spellman provides a GUI allowing customization of operational features while also providing basic power supply functionality and control via a sample simulated front panel.

Arc Intervention

Spellman's EVA power supplies sense arc events via a fast acting current sense transformer. The arc intervention circuitry prevents power supply damage from continuous, long term arcing. Customers can change arc intervention parameters (Arc Count, Arc Quench, Reramp Time, and Window Time) within preset limits via the provided GUI. Customized units can be configured for unique arc prone environments, contact Spellman for details.

Additional High Voltage Output Connectors

Spellman's EVA is designed to provide 1, 2 or 3 parallel configured high voltage output connectors. The standard unit provides one high voltage output connector. If you intend to use the EVA in a multi channel application but want to utilize your own filament power supply, this factory installed option provides the additional high voltage connections required. Hardware Option HV2 provides two high voltage output connectors, while Hardware Option HV3 provides three high voltage output connectors.

Optional Beam Controller (Filament Power Supply) and Gun Output Box



Beam Controller
1.75" (1U) Chassis

Gun Output Box

Multiple beam control units can be provided, allowing 1, 2 or 3 separate electron guns to be independently operated.

Each beam control unit consists of a beam controller and a gun output box. The beam controller is a 1U rack-mounted chassis containing the filament power, control and emission regulation circuitry. The gun output box contains the high frequency filament transformer which is referenced to the high voltage output potential. This box should be mounted close to the electron gun to minimize the length of the high current filament connections. The box also contains electron gun emission current monitoring circuitry and provides a feedback signal used to regulate the electron gun emission current.

Each beam control channel, if operated alone, can utilize 0 to 100% of the rated emission current capacity. When two or three beam control channels are used at the same time, the total system emission current capacity remains the same. Individual channel programming must be done such that the total current does not exceed the system's total emission current available.

BEAM CONTROLLER SPECIFICATIONS

Input Voltage:

180-264 Vac, 50/60Hz, single phase, 7.5 amps maximum

Output Voltage/Current:

0-12Vrms at \approx 30kHz, 0-35 amps. An optional 50 amp filament (HPF) is available.

Metering:

Front panel digital filament current and emission current meters, 3.5 digit, accurate to within 1%.

System Status Display:

"Dead Front" type indicators provide status of up to 12 system operations including voltage regulation, fault conditions and circuit control.

Input Power Connector:

A 6 foot (1.8 m) long IEC320 Cord Set will be provided.

BEAM CONTROLLER SPECIFICATIONS

Analog Interface Connector:

Male 25 pin D connector

Filament Output Connections: (gun drive cable)

The secondary leads of the filament power transformer exiting the gun output box are 36" (91.44cm) long. The cover of this box is interlocked for safety purposes.

Environmental:

Temperature Range:
Operating: 0°C to 40°C
Storage: -40°C to 85°C

Humidity:
10% to 90% RH, non-condensing.

Cooling:

Forced air; inlet through side panels, outlet at rear panel.

Dimensions:

Beam Controller:
1.75" H (1U) x 19" W x 15" D (44.5 x 482 X 381mm)
Gun Output Box:
4.06" H x 6.13" W x 11" D (103.2 x 155.7 x 279.4mm)

Weight:

Beam Controller:
18 pounds (8.1kg)
Gun Output Box:
6 pounds (2.7kg)

Emission current is programmed locally (front panel adjustment) or remotely (0-10Vdc = 0-100% of rated current) via each beam controller. Filament Limit Set Point, Filament PreHeat Set Point, and Automatic. Filament PreHeat functionality are provided.

EVA MODEL CONFIGURATION

Ordering:

EVA5N3/1PH	3 kilowatt unit, single phase
EVA10N6/3PH	6 kilowatt unit, three phase
EVA10N12/400VAC	12 kilowatt unit, 360-528Vac

Note: Input voltage must be specified at time of order. EVA model number must contain input voltage option code to be valid.

Sample Options:

EVA10N6/1PH/HV2	Single Phase Input & 2 HV Connectors
EVA10N12/400VAC/FIL3	360-528Vac Input & 3 Gun Supplies

TYPICAL EVA OPERATING SETUP

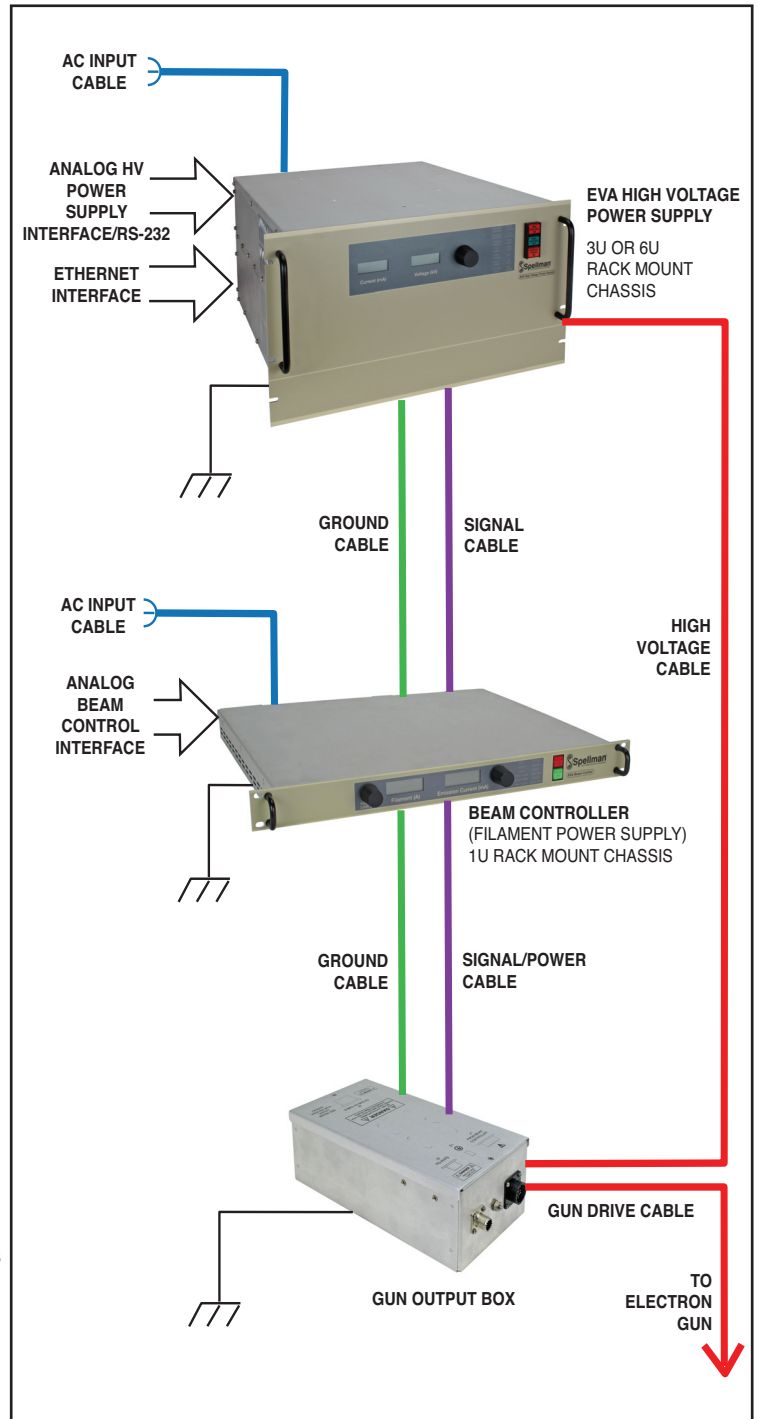

The signal cable connecting the high voltage power supply to the beam controller is 39.4" (1m) long. A captive but field replacable 10 foot (3.05m) long high voltage cable is provided to connect each beam control output box to the high voltage power supply.

HV POWER SUPPLY INTERFACE— 50 PIN FEMALE D CONNECTOR

PIN	SIGNAL	PARAMETERS
1	Power Supply Common	Power Supply Ground
2	Reset/HV Inhibit	Normally open, Low = Reset/Inhibit
3	External Interlock	+24Vdc @ open, <25mA @ closed
4	External Interlock Return	Return for External Interlock
5	mA Test Point	0-10Vdc = 0-100% rated output, Zout= 1KΩ, 1%
6	kV Test Point	0-10Vdc = 0-100% rated output, Zout= 1KΩ, 1%
7	+10Vdc Reference Output	+10Vdc @ 1mA
8	mA Program Input	0-10Vdc = 0-100% rated output, Zin>10MΩ
9	Local mA Program Output	0-10Vdc = 0-100% rated output, front panel pot
10	kV Program Input	0-10Vdc = 0-100% rated output, Zin>10MΩ
11	Local kV Program Output	0-10Vdc = 0-100% rated output, front panel pot
12	Remote Power On Output	+24Vdc @ open, <25mA @ closed
13	Remote Power On Return	Return for Remote Power On
14	Remote HV Off	+24Vdc @ open, <25mA @ closed, connect to pin15 for front panel operation
15	Remote HV Off/On Common	HV On/Off Common
16	Remote HV On	+24Vdc @ open, <25mA @ closed, momentarily connect to pin 15 enable high voltage
17	HV Off Indicator	+24Vdc @ 25mA = HV Off
18	HV On Indicator	+24Vdc @ 25mA = HV On
19	Power Supply Common	Supply Ground
20	+24Vdc Output	+24Vdc @ 100mA, maximum
21	Voltage Mode Status	Open Collector, Low = Active
22	Current Mode Status	Open Collector, Low = Active
23	Spare	
24	Interlock Closed Status	Open Collector, Low = Active
25	Spare	
26	Spare	
27	Spare	
28	Remote Overvoltage Adjust	0-10Vdc = 0-100% rated output
29	Spare	
30	Over Voltage Fault	Open Collector, Low = Active
31	Over Current Fault	Open Collector, Low = Active
32	System Fault	Open Collector, Low = Active
33	RGLT Error Fault	Open Collector, Low = Active
34	Arc	Open Collector, Low = Active
35	Over Temp Fault	Open Collector, Low = Active
36	AC Fault	Open Collector, Low = Active
37	Spare	
38	Spare	
39	Spare	
40	Spare	
41	Spare	
42	Spare	
43	Spare	
44	+5Vdc Output	+5Vdc @ 100mA, maximum
45	+15Vdc Output	+15Vdc @ 100mA, maximum
46	-15Vdc Output	-15Vdc @ 10mA, maximum
47	RS232 Tx	
48	RS232 Rx	
49	RS232 GND	
50	Power Supply Common	Power Supply Ground

BEAM CONTROLLER INTERFACE— 25 PIN FEMALE D CONNECTOR

PIN	SIGNAL	SIGNAL PARAMETERS
1	Power Supply Common	Signal Ground
2	Spare	
3	External Interlock	+15Vdc at Open, <15mA @ Closed
4	External Interlock Return	Return for Interlock
5	Filament Current Test Point	0 to 10Vdc = 0 to 100% rated output
6	Beam Current Test Point	0 to 10Vdc = 0 to 100% rated output
7	+10Vdc Reference	+10Vdc, 1mA Max
8	Filament Limit Program Input	0 to 10Vdc = 0 to 100% rated output
9	Local Filament Limit Program	Front panel potentiometer wiper
10	Beam Current Program Input	0 to 10Vdc = 0 to 100% rated output
11	Local Beam Current Program	Front panel potentiometer wiper
12	Filament Preheat Program In	0 to 10Vdc = 0 to 100% rated output
13	Local Fil. Preheat Program	Internal potentiometer
14	Beam Off	+15Vdc at Open, <25mA @ Closed
15	Beam On/Off Common	Connect together for FP operation
16	Beam On	Momentarily connect to pin 15 = Beam On
17	Remote Beam Off Indicator	0=Beam On, +15V, 10mA Max=Beam Off
18	Remote Beam On Indicator	0=Beam Off, +15V, 10mA Max=Beam On
19	Spare	
20	Spare	
21	Spare	
22	Remote PS Fault	0 = Fault, +15Vdc @ 0.1mA = No Fault
23	Spare	
24	Power Supply Common	Signal Ground
25	Shield Return	Chassis Ground

DIMENSIONS: in.[mm]

3U 6kW Power Supply

FRONT VIEW

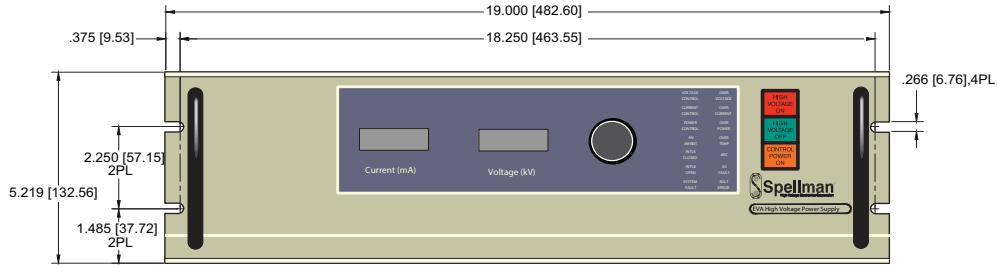

TOP VIEW



BACK VIEW

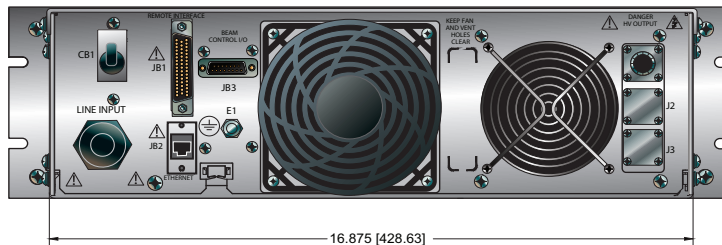

DIMENSIONS: in.[mm]

6U 12kW Power Supply

FRONT VIEW

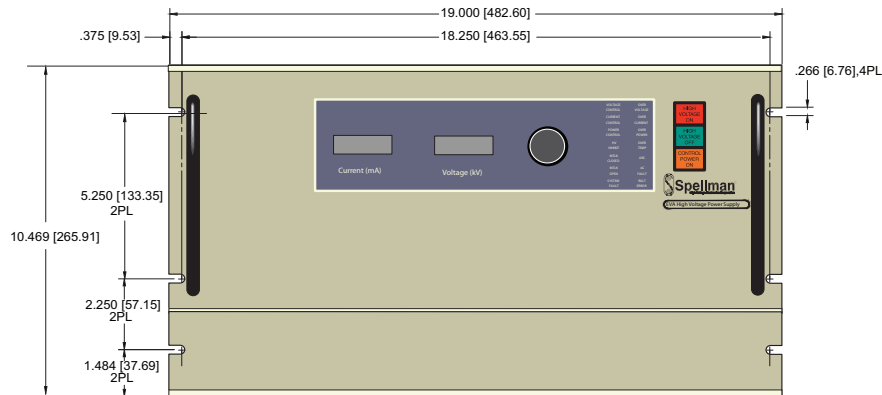

TOP VIEW



BACK VIEW

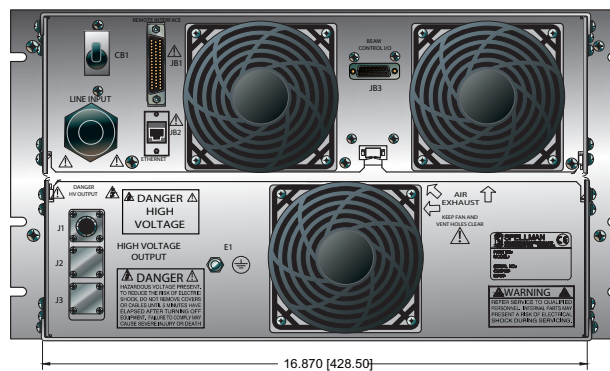

DIMENSIONS: in./[mm]
Beam Controller

FRONT VIEW

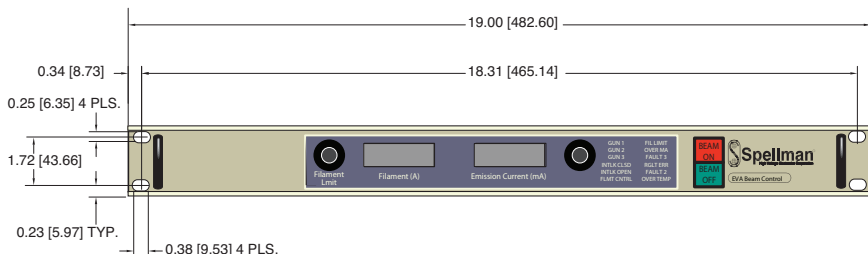

TOP VIEW

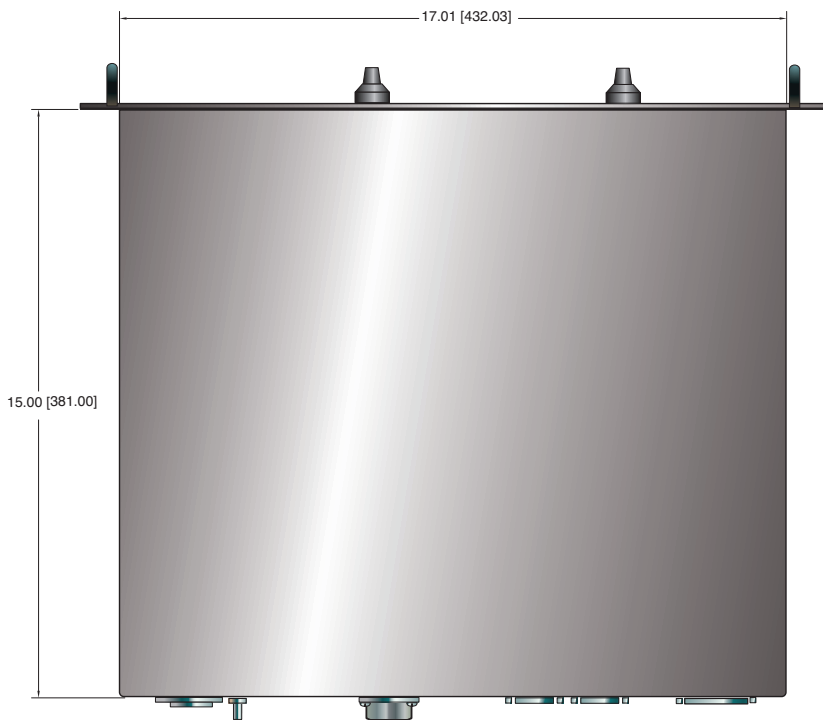

BACK VIEW

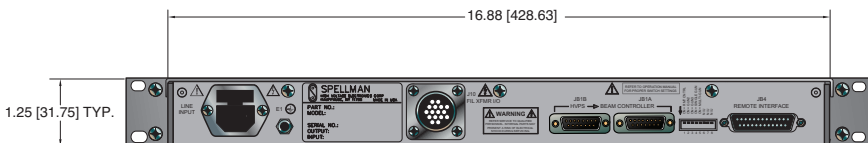

DIMENSIONS: in./[mm]
Gun Output Box

FRONT VIEW

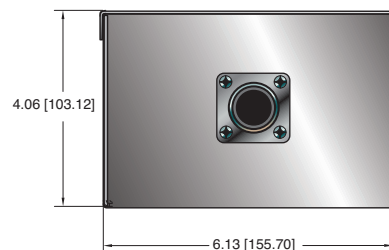

TOP VIEW

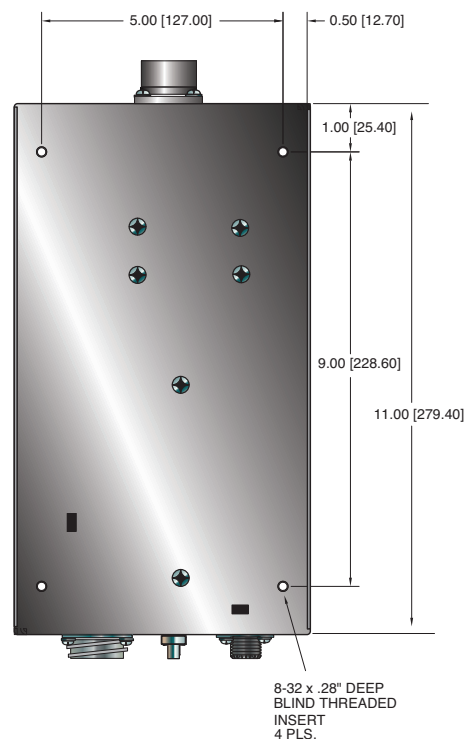

BACK VIEW

