

- **CUSTOM DESIGNED SPECIFICALLY FOR MAMMOGRAPHY APPLICATIONS**
- **COMPACT SPACE SAVING MODULAR FORMAT**
- **FAST SETTLING HELPS MINIMIZE UNNECESSARY PATIENT RADIATION EXPOSURE**
- **DUAL SPEED STARTER, BOOST/BRAKE CAPABILITY**
- **ANALOG, RS-232 AND ETHERNET INTERFACES**
- **LOW COST, VALUE ADDED DESIGN**

Spellman's VMX redefines the standard for high performance, low cost Mammography X-Ray generators. The VMX was born from an integrated, high performance, value added design perspective so there's no need to compromise critical specifications to meet ever demanding system price targets.

The 40kV @ 5kW (peak) high voltage output coupled with a dual focal spot, DC current source filament power supply provides fast rise times with stable and accurate X-Ray tube emission currents. The solid encapsulated high voltage output section eliminates oil concerns while reducing the effects of environmental humidity and contamination.

Flexibility in interfacing is provided via a ground referenced 0-10Vdc analog interface, RS-232 and Ethernet connectivity. The VMX features a dual speed starter with boost and brake functionality which can be custom configured via the digital interface. Compact, full featured, high performance, low cost... Spellman's VMX, the next generation Mammography X-Ray generator.

### SPECIFICATIONS

#### Input Voltage:

180-264Vac, single phase, 50Hz/60Hz

#### Input Current:

50A service recommended for 5kW operation  
 External EMC Filter (required to meet CE/EMC specifications) – Optional\*  
 Mains Contactor – Not provided within the generator.  
 Customer is responsible for mains safety disconnection.

#### Output Voltage

##### Output Voltage Range:

20kV to 40kV

##### Polarity:

Positive, grounded cathode X-ray tube

##### Accuracy:

Within 1% of programmed values

##### Reproductibility:

<0.5%

##### Setting Time:

<10ms

#### Ripple:

≤1%

#### Stability:

≤0.01% per 8 hours

#### Temperature Coefficient:

≤100ppm/°C

#### Output Current/Power

##### Output Current Range:

10mA to 200mA

##### Output Power:

5kW peak, ~30W average (0.6% duty cycle)

##### Maximum mAs:

500mAs

##### Maximum Exposure Time:

5 seconds

##### Accuracy:

Within 2% of programmed values

##### Reproductibility:

<0.5%

##### Setting Time:

<10ms

#### Filament Configuration

DC filament drive with closed loop emission control circuitry that adjusts filament setting to provide regulated X Ray tube emission current

##### Filament Output:

0-6 amps at a compliance of 5.5 volts, maximum.  
 Dual focal spot

##### Starter:

Dual Speed Starter: High speed (180Hz) and low speed (60Hz) can be configured via the serial interface.  
 Boost and Brake capability provided.

##### AC Input Connector:

3 position terminal block

##### Analog Interface Connector:

25 pin male D connector

##### Rotor Interface Connector:

4 position terminal block

##### Tube/Interlock Connector:

16 position terminal block

**High Voltage Connector:**

60kV, Claymount CA-3 type or equivalent

**Digital Interface:**

Ethernet (RJ45)

**Grounding Point:**

M5 blind insert provided on chassis

**Environmental:**

Temperature Range:  
 Operating: 10°C to 40°C  
 Storage: -40°C to 85°C

Humidity:  
 20% to 85% RH, non-condensing.

**Cooling:**

Convection cooled, no internal fans.  
 Forced air cooling not required

**Dimensions:**

9.38" H X 6.6" W X 12" D  
 (237.5mm x 167.6mm x 304.8mm)

**Weight:**

<22 pounds (10kg)

**Regulatory Approvals:**

Compliant to 2004/108/EC, the EMC Directive and 2006/95/EC, the Low Voltage Directive (pending). IEC60601-1, IEC60601-1-2 and IEC60601-2-45 (pending)

**VMX STANDARD SYSTEM INTERFACE— JB1 25 PIN MALE D CONNECTOR**

PIN	SIGNAL	PARAMETERS
1	GND	Signal Ground
2	+5Vdc Out	+5Vdc, 100mA max.
3	RS-232 Tx Out	RS-232 Transmit
4	RS-232 Rx In	RS-232 Receive
5	PREP	User signal (Contact Closure) to alert the generator that exposure sequence will begin. Once this signal is active, exposure parameters are locked in and cannot be changed. The generator enables the starter to boost the rotor. Contact connection to pin 24. Closed = PREP, the filament is placed in preheat mode
6	READY	Generator signal to user to indicate the rotor runs to speed and the generator is ready for X-ray exposure Open Collector. Low/Active = Ready
7	ROTOR SHUTDOWN	User signal to brake the rotor drive
8	EXPOSURE	User signal (Contact Closure) to generator to generate X-Rays. Filament is boosted, and high voltage is generated after the boost time. Contact connection to pin 24. Closed = Exposure
9	X-Ray ON Status	Relay contacts (N.O.) to indicate X-Ray ON status (Closes to common, pin 11)
10	X-Ray OFF Status	Relay contacts (N.C.) to indicate X-Ray OFF status (Closes to common, pin 11)
11	X-Ray COMMON Status	Relay common (C) for X-Ray ON/OFF status Relay contacts 24Vdc, 1A max.
12	X-Ray SHUTDOWN/AEC	User signal to generator to rapidly turn HV OFF and ON during exposure (AEC)
13	FIL SELECT	User signal to generator to select large or small filament drive. OPEN = Large, GROUNDED = Small
14	HVG FAULT Status	Generator signal indicating generator fault. Open collector transistor output. Low/Active = Fault
15	Status Bit 1	3 bit status lines for up to 6 status messages. See separate matrix describing functionality. Open Collector. Low/Active = Message
16	Status Bit 2	
17	Status Bit 3	
18	kV Program	User signal to generator for analog programming of tube voltage. 0-10V = 0-40kV
19	Emission Program	User signal to generator for analog programming of emission current. 0-10V = 0-200mA
20	kV Monitor	Signal from generator. 0-10V = 0-40kV. Zout = 1kΩ
21	Emission Monitor	Signal from generator. 0-10V = 0-200mA. Zout = 1kΩ
22	Filament Current Monitor	Signal from generator. 0-10V = 0-6A. Zout = 1kΩ
23	Program/Monitor Return	Ground for reference of program and monitor signals
24	+24Vdc Out	For connection to PREP and EXPOSURE control relay coils
25	SHIELD/GND	For connection of interface cable shield to generator chassis ground

**OPTIONAL SYSTEM COMMUNICATION INTERFACE— JB3 8 PIN RJ45 CONNECTOR**

PIN	SIGNAL	PARAMETERS
1	TX+ White/Orange	10/100 Base-T Interface
2	TX- Orange	
3	RX+ White/Green	
4	POE V+ Blue	
5	POE V+ Blue/White	
6	RX- Green	
7	POE V- Brown/White	
8	POE V- Brown	

### TB1 MAINS INPUT

PIN	SIGNAL	PARAMETERS
1	Earth Ground	Connection to earth ground
2	Line 1	AC line input, 180-264Vac, 47-63Hz, 50A service recommended for 5kW operation
3	Line 2	

### TB2 ROTOR INTERFACE

PIN	SIGNAL	PARAMETERS
1	MAIN	Stator winding Phase A
2	PHASE	Stator winding Phase B
3	COM	Stator winding Phase C
4	GND	Ground for cable shield/tube housing

### TB3 TUBE AND INTERLOCK INTERFACE

PIN	SIGNAL	PARAMETERS
1	Small Filament	Connection to tube Small Filament
2	Filament Common	Connection to tube Filament Common
3	Large Filament	Connection to tube Large Filament
4	Ground	Generator Chassis for cable shield connection
5	Tube Temp +	Used if tube has separate thermostat switch. Open = over temp (short terminals if not used)
6	Tube Temp -	
7	Tube Flow +	Used if tube has cooling circulator flow switch. Open = no flow (short terminals if not used)
8	Tube Flow -	
9	Safety Interlock +	User signal (contact closure) for safety interlocks such as door interlocks. Open turns HV OFF, or inhibits HV from being generated. Closed = OK 24Vdc @ <1A typical
10	Safety Interlock -	
11	Contactor Coil (+)	Option for contactor coil control
12	Contactor Coil (-)	

### J1 HV OUTPUT: CA3 TYPE

PIN	SIGNAL	PARAMETERS
1	HV Output	0-40kV, 200mA, 500mAs, 5kW peak, 30W average

DIMENSIONS: in.[mm]

#### FRONT VIEW

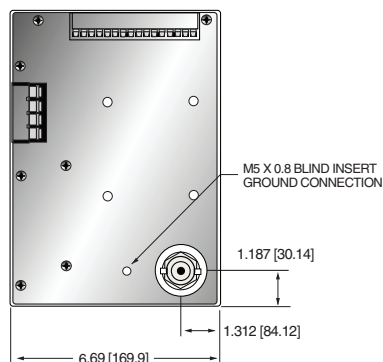

#### TOP VIEW

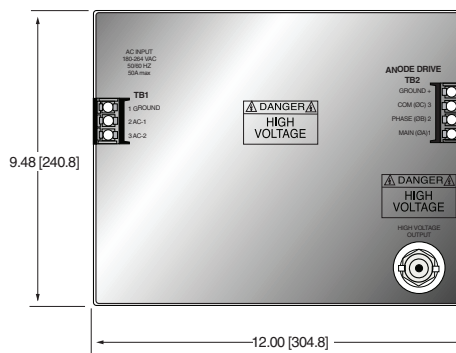

#### BOTTOM VIEW

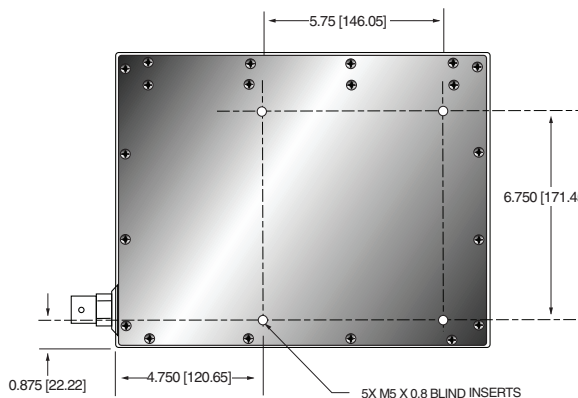

#### SIDE VIEW

