

# Instruction Manual

SL150kV

## High Voltage Power Supply

MODEL :  
SERIAL# :  
DATE :

**SPELLMAN  
HIGH VOLTAGE ELECTRONICS  
CORPORATION**

475 Wireless Blvd.  
Hauppauge, New York, 11788

+1(631) 630-3000\*FAX: +1(631) 435-1620\*  
E-mail: [sales@spellmanhv.com](mailto:sales@spellmanhv.com)  
Website: [www.spellmanhv.com](http://www.spellmanhv.com)



Spellman's SL150kV rack mount high voltage power supply is designed for scientific and industrial OEM applications requiring 150kV at 1200 watts in a compact cable connected standard sized rack. Models are available in positive, negative or reversible polarity. The SL150kV is fully arc and short circuit protected. Excellent regulation specifications are provided along with outstanding stability performance. The vacuum encapsulated high voltage output section assures reliable corona free operation by eliminating any concerns due to environmental factors.

## TYPICAL APPLICATIONS

Electrostatics  
HiPot Testing  
Semiconductor Processing  
Capacitor Charging

## OPTIONS

<b>200</b>	200Vac Input Voltage
<b>AOL</b>	Adjustable Overload Trip
<b>APT</b>	Adjustable Power Trip
<b>AT</b>	Arc Trip
<b>BFP</b>	Blank Front Panel
<b>CPC</b>	Constant Power Control
<b>DPM4</b>	4.5 Digit Panel Meters
<b>EFR</b>	External Fault Relay
<b>LL(X)</b>	Non-Standard HV Cable Length (10 standard)
<b>NAD</b>	No Arc Detect
<b>NSS</b>	No Slow Start
<b>RFR</b>	Remote Fault Reset
<b>SS(X)</b>	Non-Standard Slow Start (6 seconds standard)

- **CABLE CONNECTED 150kV @ 1200W POWER SUPPLY**
- **REQUIRES ONLY 8.75" (5U) PANEL HEIGHT**
- **EXTENSIVE ANALOG INTERFACE**
- **ARC QUENCH/ARC COUNT/ARC TRIP**
- **COMPREHENSIVE DIGITAL FAULT DIAGNOSTICS**

[www.spellmanhv.com/manuals/SL150KV](http://www.spellmanhv.com/manuals/SL150KV)

## SPECIFICATIONS

### Front Panel Controls:

Front Panel Controls Power ON/OFF switch, HV ON Switch, HV OFF Switch with preset feature, 3.5 digit backlight digital meters for display of output voltage and output current, 10 turn locking potentiometers with counting dials for adjustment of both output voltage and output current.

### Front Panel Indicators:

HV ON	High Voltage Inhibit
HV OFF	Over Current
Voltage Control Mode	Over Voltage
Current Control Mode	Arc
Interlock Open	Regulation Error
Interlock Closed	Overtemperature

### Input:

220Vac  $\pm 10\%$ , 50/60 Hertz

### Output Voltage:

0 to 150kV

### Output Polarity:

Positive, negative or reversible specify at time of order

### Output Current:

8mA

### Output Power:

1200W

### Voltage Regulation:

Load: 0.01% of rated voltage for a full load change  
Line:  $\pm 0.01\%$  of rated current over specified input voltage range

### Current Regulation:

Load: 0.01% of rated current  $\pm 100\mu\text{A}$  for full voltage change.  
Line:  $\pm 0.01\%$  of rated current over specified input voltage range

### Ripple:

0.1% peak to peak of maximum output

### Temperature Coefficient:

100ppm/ $^{\circ}\text{C}$ .

### Stability:

100ppm/hr after a 2 hour warm up, for both voltage and current regulation

**Operating Temperature:**  
0 to 40°C operating

**Storage Temperature:**  
-40 to +85°C storage

**Humidity:**  
20% to 85%, non-condensing

**Input Line Connector:**  
3 conductor 12 AWG 6 ft (1.83m) cable, permanently attached

**Output Connector:**  
A detachable 10 ft (3.05m) shielded HV cable is provided

**Cooling:**  
Forced Air

**Dimensions:**  
8.75"H x 19"W x 22"D rack mount.  
(22.23cm x 48.26cm x 55.88cm)

**Weight:**  
89 pounds (40.4kg)

**Regulatory Approvals:**  
Compliant to 2004/108/EC, the EMC Directive  
and 2006/95/EC, the Low Voltage Directive.

DIMENSIONS: in.[mm]

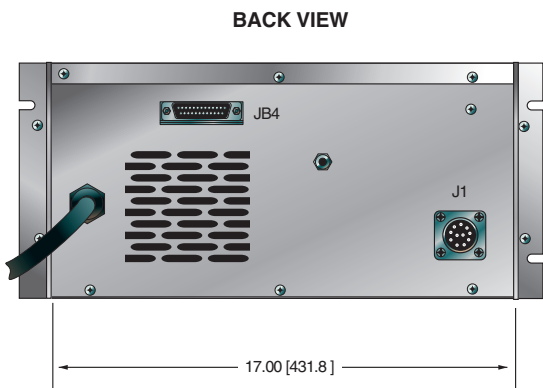
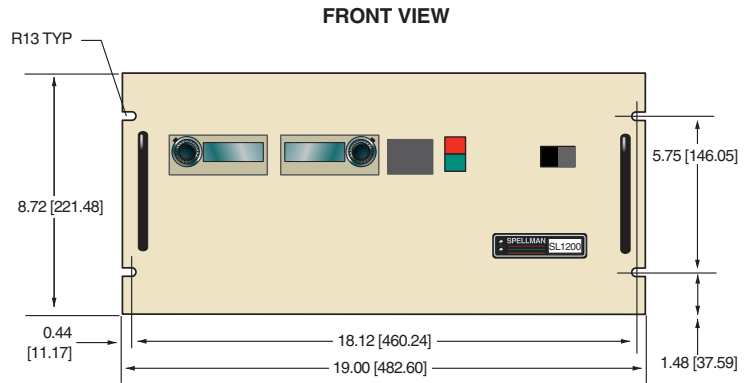

## SL150 ANALOG INTERFACE— JB4 25 PIN MALE D CONNECTOR

PIN	SIGNAL	PARAMETERS
1	Power Supply Common	Signal Ground
2	External Inhibit	Ground = Inhibit, Open = HV ON
3	External Interlock	+15Vdc @ open, ≤ 5mA @ closed
4	External Interlock Return	Connect to pin 3 to enable supply
5	Current Monitor	0 to 10Vdc = 0 to 100% rated voltage, Zout = 10kΩ
6	Voltage Monitor	0 to 10Vdc = 0 to 100% rated voltage, Zout = 10kΩ
7	+10Vdc Reference	+10Vdc @ 1mA, maximum
8	Remote Current Program Input	0 to 10Vdc = 0 to 100% rated voltage, Zout = 10kΩ
9	Local Current Program Output	Multi-turn front panel pot for local control capability
10	Remote Voltage Program Input	0 to 10Vdc = 0 to 100% rated voltage, Zout = 10kΩ
11	Local Voltage Program Output	Multi-turn front panel pot for local control capability
12	EFR (Common)	External Fault Relay (Optional)
13	EFR (Normally Open)	External Fault Relay (Optional)
14	Local HV OFF OUT	+15Vdc @ open, <25mA @ closed, connect to HV OFF for front panel operation
15	HV OFF	Connect to HV OFF OUT for front panel operation
16	Remote HV ON	+15Vdc @ 10mA maximum = HV OFF
17	Remote HV OFF Indicator	0 = HV ON, +15Vdc @ 10mA maximum = HV OFF
18	Remote HV ON Indicator	0 = HV OFF, +15Vdc @ 10mA maximum = HV ON
19	Remote Voltage Mode	Open collector 50Vdc @ 10mA maximum, ON = Active
20	Remote Current Mode	Open collector 50Vdc @ 10mA maximum, ON = Active
21	Remote Power Mode	Open collector 50Vdc @ 10mA maximum, ON = Active
22	Power Supply Fault	Open collector, 50Vdc @ 10mA maximum
23	+15Vdc Output	+15Vdc @ 100mA, maximum
24	Power Supply Ground	Signal Ground
25	Shield Return	Chassis Ground

Specify "P" for positive polarity or "N" for negative polarity, and PN = reversible as illustrated below.

Sample Model Number: SL150P1200/BFP/LL(20)  
Where SL = power supply series, 150 = maximum output voltage in kV,  
P = positive output polarity, 1200 = maximum output power (watts), BFP = Blank Front Panel, LL(20) = 20 foot HV cable.

## IMPORTANT SAFETY PRECAUTIONS

### SAFETY

THIS POWER SUPPLY GENERATES VOLTAGES THAT ARE DANGEROUS AND MAY BE FATAL.  
OBSERVE EXTREME CAUTION WHEN WORKING WITH THIS EQUIPMENT.

High voltage power supplies must always be grounded.

Do not touch connections unless the equipment is off and the Capacitance of both the load and power supply is discharged.

Allow five minutes for discharge of internal capacitance of the power supply.

Do not ground yourself or work under wet or damp conditions.

### SERVICING SAFETY

Maintenance may require removing the instrument cover with the power on.

Servicing should be done by qualified personnel aware of the electrical hazards.

**WARNING** note in the text call attention to hazards in operation of these units that could lead to possible injury or death.

**CAUTION** notes in the text indicate procedures to be followed to avoid possible damage to equipment.

Copyright © 2000, Spellman High Voltage Electronics Corporation. All Rights Reserved.  
This information contained in this publication is derived in part from proprietary and patent data. This information has been prepared for the express purpose of assisting operating and maintenance personnel in the efficient use of the model described herein, and publication of this information does not convey any right to reproduce it or to use it for any purpose other than in connection with installation, operation, and maintenance of the equipment described.

# Table of Contents

	<b>PAGE</b>
<b>1. INTRODUCTION</b>	
1.1 Description of the SL150 .....	1
1.2 Standard Features .....	2
1.2.1 Remote Operating Features .....	2
1.2.2 System Status and Fault Diagnostic Display .....	2
1.3 Options .....	3
1.4 Interpreting the Model Number .....	4
<b>2. INSPECTION &amp; INSTALLATION</b>	
2.1 Initial Inspection .....	5
2.2 Mechanical Installation .....	5
<b>3. OPERATING INSTRUCTIONS</b>	
3.1 Operation .....	7
3.2 Standard Features .....	8
<b>4. PRINCIPLES OF OPERATION</b>	
4.1 Chassis .....	17
4.2 High Voltage Transformer .....	18
4.3 High Voltage Assembly .....	18
4.4 Control/Power PWB .....	18
4.5 Front Panel Assembly .....	18
4.6 Options .....	18
<b>5. OPTIONS</b>	
5.1 Adjustable Overload Trip .....	19
5.2 200Vac Single Phase Input .....	19
5.3 No Slow Start .....	19
5.4 Non-Standard Slow Start .....	19
5.5 Extra Length Output Cable .....	19
5.6 Arc Trip Option .....	19
5.7 Reversible Polarity Option .....	19
5.8 Adjustable Power Trip/Constant Power Control .....	19
5.9 External Fault Relay Option .....	20
5.10 NAD Option .....	20
5.11 RFR Option .....	20
5.12 Custom Design Models .....	20

**6. MAINTENANCE**

6.1 Periodic Servicing .....23  
6.2 Performance Test .....23  
6.3 High Voltage Dividers .....23

**7. REPLACEMENT PARTS**

7.1 Replacement Parts.....24  
7.2 Correspondence and Ordering Spare Parts .....24

**8. FACTORY SERVICE**

8.1 Warranty Repairs .....25  
8.2 Factory Service Procedures .....25  
8.3 Ordering Options and Modifications .....25  
8.4 Shipping Instructions .....25

**LIST OF FIGURES**

Figure 2.1 SL150 Dimensions.....6  
Figure 3.1 SL150 Typical Operating Set Up.....10  
Figure 3.2A Wiring Diagram for Remote Programming via Voltage Source .....12  
Figure 3.2B Wiring Diagram for Remote Programming via External Resistance.....12  
Figure 3.3 Remote Monitor Test Point Designations.....13  
Figure 3.4 Remote Control of High Voltage On and Off .....13  
Figure 3.5 External Inhibit Interface Circuit.....14  
Figure 3.6 External Interlock Interface Circuit .....14  
Figure 3.7 Remote High Voltage On and Remote High Voltage off Indicator Circuit.... 15  
Figure 3.8 Remote Indicators Interface ..... 16  
Figure 5.1 Adjustable Power Remote Interface Control .....21  
Figure 5.2 Reverse Polarity Option .....22

**LIST OF TABLES**

Table 1.1 SL150 Options .....3  
Table 3.1 Rear Panel Interface 25 pin Mini D .....11

**APPENDIX**

- A. Specification Controls (Custom Models Only)

# Chapter 1

## INTRODUCTION

### 1.1 Description of the SL150

The SL150 voltage power supply provides very well regulated, low ripple high voltage in a highly efficient, compact design. The improvements in size and performance over traditionally designed high voltage power supplies are due to the resonant topology and unique control circuitry of the SL design. A proprietary control system maintains high frequency over the operating output range. High frequency operation allows a dynamic response time of less than 5 milliseconds, and one of the lowest ripple specifications in the industry at this power level. The combination of proprietary control system and proprietary protection circuitry enables the supplies to operate under arcing and extreme transient conditions without damage or interruptions.

The DC output voltage and current are continuously adjustable from zero to the maximum rating via two front panel ten-turn locking potentiometers. These high voltage power supplies have 0.005% load regulation, 0.005% line regulation, and 0.1% p-p ripple.

The supplies operate from either a 200 (option) or 220 Volt, single phase AC line. Other line voltages are available. Options are listed in Table 1.1 and are described in Section 5. Custom designed units to meet special needs are also available.

## 1.2 Standard Features

The SL150 incorporates several standard features designed to optimize user satisfaction and safety.

- **SLOW START:** This feature provides a gradual increase in high voltage until the preset operating point is reached. The slow start time is factory set for 6 seconds. Other slow start times are available as an option.
- **ARC DETECT / ARC QUENCH / ARC COUNT:** These features allow the user to tailor the power supply to meet specific needs in dynamic load applications. If an arc occurs, the output is inhibited for approximately one second, then the output is ramped up to the preset level with the slow-start circuitry. See Chapter 3 for operating details and information for user customization of these features.
- **INTERNAL FAULT PROTECTION:** The SL Series continually monitors internal circuits critical to the proper operation of the power supply. In the event that one of these circuits does not function correctly, the fault detection circuit latches the appropriate fault on the front panel display and turns off the output and reverts the unit to the POWER DOWN mode.
- **INDICATOR LAMPS:** LINE POWER, HIGH VOLTAGE OFF AND HIGH VOLTAGE ON indicators.
- **OUTPUT CABLE:** All models are provided with a ten foot shielded high voltage output cable. The cables are designed with a plug arrangement so that they can be easily removed from the mating receptacle located on the rear of the chassis.

### 1.2.1 Remote Operating Features

- **REMOTE PROGRAMMING:** Allows remote adjustment of the output voltage and current via an external voltage source. The output power is also remotely controllable when the CPC or APT option is ordered, TB1 only.
- **REMOTE MONITOR:** Allows remote monitoring of the output voltage and current.

**NOTE:** Output power remote monitor is included with the CPC and APT options, TB1 only.

- **REMOTE HIGH VOLTAGE CONTROL:** Allows remote control of HIGH VOLTAGE ON and HIGH VOLTAGE OFF. Signals are also provided for remote indication of HV ON or HV OFF status.
- **EXTERNAL INHIBIT:** A control signal that will inhibit the high voltage output is provided on the external interface. A logic low, ground, will inhibit the high voltage output and a logic high, open, will restore the high voltage output to the preset level.

**NOTE:** The External Inhibit circuit should NOT be used for protection against injury or for safety interlock. See External Interlock for this type of safety control.

- **EXTERNAL INTERLOCK:** Interlock connections are provided on the external interface on the rear of the chassis for connection to a safety switch. The unit will not operate unless the interlock circuit is closed. During high voltage operation, opening the interlock circuit will cause the High Voltage to shut off. This circuit should be used for safety interlock circuits.

### 1.2.2 System Status and Fault Diagnostic Display

“Dead Front” type indicators are provided to give the user complete indication of system operation and fault conditions. If a fault occurs, the power supply will revert to the POWER DOWN mode. This is indicated by both the HV ON and HV OFF lamps turning off. To reset, depress the HV OFF switch.

- **VOLTAGE (CONTROL):** Indicates the output voltage regulator circuit is maintaining voltage regulation.
- **CURRENT (CONTROL):** Indicates the output current regulator circuit is maintaining current regulation.
- **POWER (CONTROL):** Indicates the output power regulator circuit is maintaining power regulation (optional).
- **HV INHIBIT:** Indicates that the high voltage supply is being inhibited by either the EXTERNAL INHIBIT or internal protection circuitry.
- **INTLK CLSD:** Indicates the EXTERNAL INTERLOCK connections are in the closed position. This also indicates closure of internal power supply interlocks.

- **INTKL OPEN:** Indicates the EXTERNAL INTERLOCK connections are in the open position. This also indicates opening of internal power supply interlocks.
- **OVERVOLT:** Indicates the overvoltage protection circuitry has caused the power supply to turn off. Overvoltage protection is internally set to 110% of the rated output voltage.
- **OVERCURR:** Indicates the output current has exceeded the programmed current trip level when the AOL (Adjustable Overload Trip) or the OL (Overload Trip) options are installed.
- **OVERPOWER:** Indicates the output power has exceeded the internally set level or the remote programmed level if the optional circuitry is installed.
- **ARC:** Indicates that an arc has occurred within the previous one second or that the ARC COUNT/TRIP has shutdown the power supply.
- **RGLT ERR:** Indicates a failure in the voltage, current or power regulation circuitry. This fault usually occurs when there is a lack of output power to maintain regulation.

The options available are listed in Table 1.1. See Section 5 for more information on these options along with operating and set-up instructions. With few exceptions, these options and modifications can be retrofitted to your power supply at the factory in a short time. For price and retrofit arrangements, contact the Spellman Sales Department.

### 1.3 Options

AOL	Adjustable Overload Trip (0-103%)
APT	Adjustable Power Trip
AT	Arc Trip
CPC	Constant Power Control
SS(x)	Non-Standard Slow Start
NSS	No Slow Start
LR	Low Ripple (0.05% p-p)
DPM4	4 1/2 Digit $\pm$ 1 Least Significant Digit Panel Mtr
PN	Reversible Polarity
LL (x)	Extra Length Output Cable in Feet
EFR	External Fault Relay
BFP	Blank Front Panel
NAD	No ARC Detect
RFR	Remote Fault Reset

**Table 1.1 SL150 Options**

Note: APT/CPC cannot be combined with EFR

## 1.4 Interpreting the Model Number

The model number of the power supply describes its capabilities. After the series name is:

1. the maximum voltage (in kV).
2. the polarity of the unit: positive (P), negative (N) or reversible (PN).
3. the maximum output (in watts).
4. the option codes for all options that are included.

Custom units have an X number after the option codes.

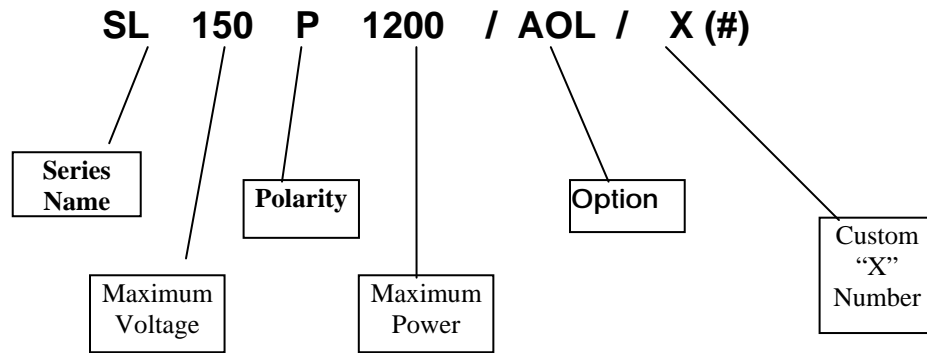

# Chapter 2

## INSPECTION & INSTALLATION

**I**nitial inspection and preliminary checkout procedures are recommended. For safe operation, please follow the step-by-step procedures described in Chapter 3, Operating Systems.

### 2.1 Initial Inspection

Inspect the package exterior for evidence of damage due to handling in transit. Notify the carrier and Spellman immediately if damage is evident. Do not destroy or remove any of the packing material used in a damaged shipment.

After unpacking, inspect the panel and chassis for visible damage.

Fill out and mail the Warranty Registration card accompanying the unit. Standard Spellman SL Series high voltage power supplies and components are covered by warranty. Custom and special order models (with an X suffix and the model number) are also covered by warranty.

### 2.2 Mechanical Installation

Units in the SL Series have front panel holes for standard EIA rack mounting. The rack must allow rear access for cable connections. Units are fully enclosed and are suitable for bench or table top operation. Standard unit dimensions are shown in Figure 2.1.

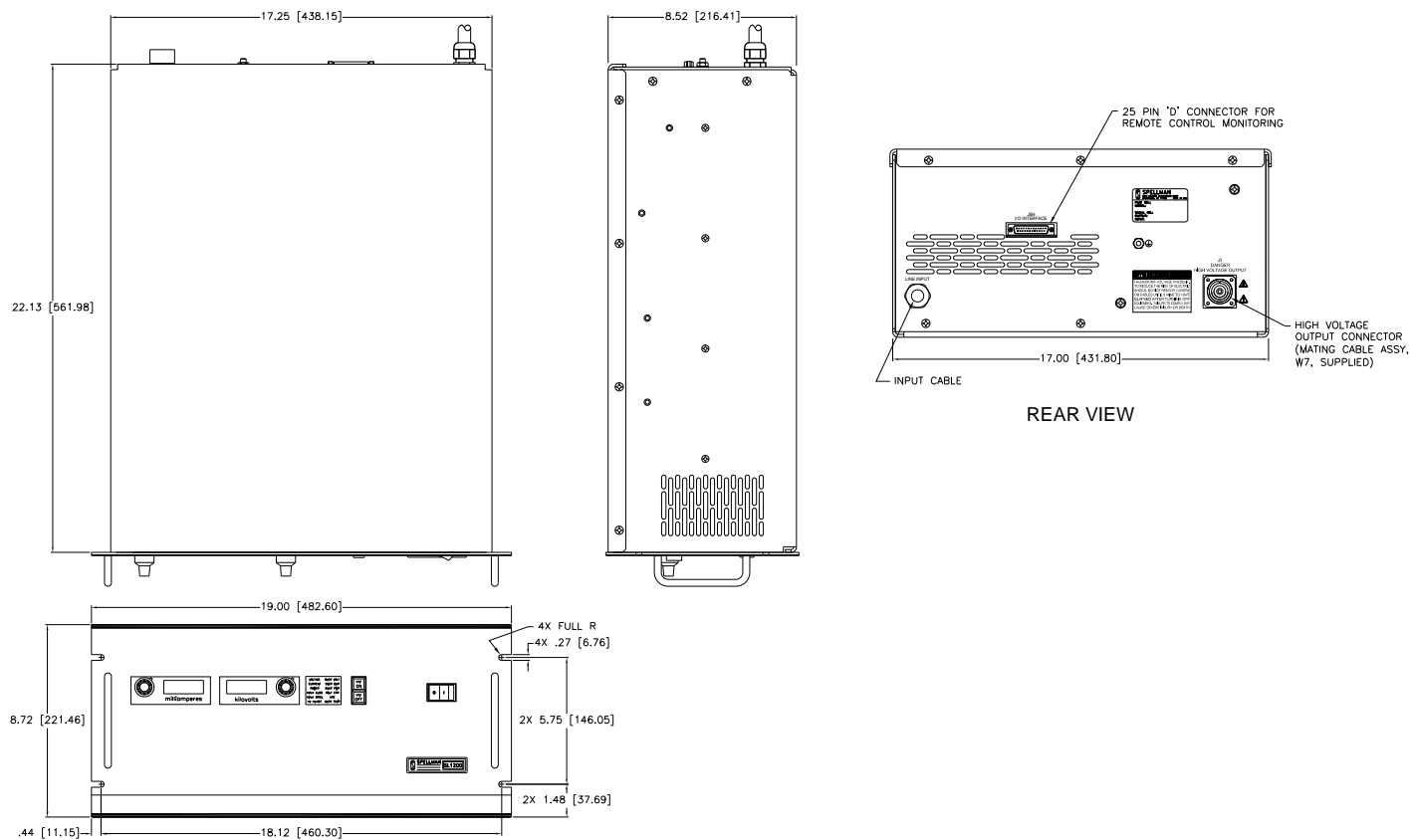

Figure 2.1 SL150 Dimensions

# Chapter 3

## OPERATING INSTRUCTIONS

### 3.1 Operation

**WARNING**

**THIS EQUIPMENT GENERATES DANGEROUS VOLTAGES THAT MAY BE FATAL.**

**PROPER GROUNDING OF ALL HIGH VOLTAGE EQUIPMENT IS ESSENTIAL.**

**WARNING**

**BEFORE CONNECTING THE POWER SUPPLY TO THE AC LINE, FOLLOW THIS STEP BY STEP PROCEDURE.**

**DO NOT CONNECT THE POWER SUPPLY TO THE AC LINE UNTIL STEP H IS REACHED.**

Failure to follow these procedures may void the warranty.

- A) Insure that the Circuit Breaker is in the OFF position (0).
- B) Check the input voltage rating on the nameplate of the supply and make certain that this is the rating of the available power source.
- C) **PROPER GROUNDING TECHNIQUES:** The chassis of high voltage power supplies must be grounded, preferably to a water system ground using copper pipe or other earth ground using the ground stud B1 at the rear of the unit. See Figure 3.1 for a typical operating set-up.

The return line from the load should be connected to the ground stud on the rear of the power supply. Using a separate external ground at the load is not recommended.

- D) Attach the output cable to the load.

- E) Plug the high-voltage output cable provided with the unit into the rear of the supply and hand tighten the knurled collar.
- F) **OPTIONS NOTE:** See Section 5 for hook-up and operating instructions for the options on your unit. Custom models may also require set-up changes.
- G) For initial turn-on, rotate the KILOVOLT control fully counter-clockwise to the zero voltage position.
- H) The input power cable may now be connected to the AC power line.
- I) Switch the front panel circuit breaker to the ON position (1). (If the supply is to be turned off for an extensive period of time, the line cord should be disconnected). The unit is now in the HIGH VOLTAGE OFF mode. The HIGH VOLTAGE OFF light should be lit.

## CAUTION

- J) Depress and hold the HIGH VOLTAGE OFF switch. The front panel meters will now read the preset value of the KILOVOLT control dial and the MILLIAMPERES control dial. To preset the desired level of current and voltage during operation, hold in the HIGH VOLTAGE OFF switch and rotate the appropriate control dial while noting its corresponding meter reading. Release the HIGH VOLTAGE OFF switch.

**NOTE:** No actual output is being produced at this stage.

- K) Depress the HIGH VOLTAGE ON switch. The light inside the switch should light up and the output will slow start to the preset level output voltage and/or output current.

**NOTE:** The SL Series is equipped with a slow start circuit that ramps the output up to its maximum setting in approximately 6 seconds after the HIGH VOLTAGE ON switch is depressed.

- L) To terminate the generation of output power, depress the HIGH VOLTAGE OFF switch. In the HIGH VOLTAGE OFF mode the power supply's fault and interface circuits are still active.

- M) To turn off the power supply, turn the circuit breaker to the off position (0).

**NOTE:** If a power supply fault, or system monitoring fault occurs, the power supply will revert to the POWER DOWN mode. In this mode the output power will be turned off. The HV OFF lamp will be off. To reset, depress the HV OFF switch.

## WARNING

**AFTER TURNOFF, DO NOT HANDLE THE LOAD UNTIL THE CAPACITANCE HAS BEEN DISCHARGED!**

**LOAD CAPACITANCE MAY BE DISCHARGED BY SHORTING TO GROUND.**

## WARNING

**THE VOLTMETER ON THE POWER SUPPLY FRONT PANEL DOES NOT READ THE OUTPUT VOLTAGE WHEN THE POWER IS TURNED OFF, EVEN IF A CHARGE STILL EXISTS ON THE LOAD.**

## ALWAYS OPERATE THE UNIT WITH THE COVER ON.

A fan maintains safe operating temperature in the power supplies by drawing air over the circuit components. The cover must be on in order to direct the air flow over the areas that need cooling. In operation, the unit must be placed so that the air intake and the fan exhaust are clear of obstructions that might impede the flow of air.

## 3.2 Standard Features

A note on remote interface circuitry and remote signal grounding. Whenever possible, electrical isolation should be provided when interfacing with any high voltage power supply. For power control signals such as EXTERNAL INTERLOCK, HIGH VOLTAGE OFF, AND HIGH VOLTAGE ON, isolated relay contacts should be used. For status signals and control signals such as HIGH VOLTAGE ON, HIGH VOLTAGE OFF, and EXTERNAL INHIBIT, etc., opto-isolation should be used. If possible, analog programming and monitoring signals should be isolated via analog isolation amplifiers. Spellman application engineers are available to assist in interface circuitry design. All interface cables should be properly shielded. All power supply signals should be referenced to the power supplies signal ground on the rear external interface.

- **REMOTE PROGRAMMING:** Allows remote adjustment of the output voltage and current via an external voltage source. (Output power is also remotely controllable with the CPC and APT options). In local control (front panel control), jumpers are installed on the external interface JB4 in the rear of the chassis between JB4-10 and JB4-11 for voltage control and between JB4-8 and JB4-9 for current control.

For remote programming, the jumpers are removed and a positive voltage source, from 0V to 10V, is applied to the appropriate terminals. Programming signals should be referenced to JB4-1, signal ground. By adjusting the voltage source from 0V (zero output) to 10V (full rated output), the desired output can be selected. See Figure 3.2A on page 12 for the wiring diagram and specifications.

An alternate method of controlling the output remotely is by using external resistance, such as a potentiometer or a resistor network. For remote control the jumpers are removed and the desired register configuration installed. See Figure 3.2B on page 12 for the wiring diagram.

- **REMOTE MONITOR:** Test points are made available at the terminal block on the rear of the chassis for monitoring the voltage and current output. (Output power monitor is included with the CPC and APT option). The test points are always positive regardless of the output polarity where 0V to 10V equals 0 to 100% of the output  $\pm 0.5\%$ . Test points have an output impedance of 5K ohms. See Figure 3.3 on page 13 for the test point designation.
- **REMOTE CONTROL:** Remote control of the HIGH VOLTAGE ON and HIGH VOLTAGE OFF can be accomplished via the rear panel interface. HIGH VOLTAGE OFF and HIGH VOLTAGE ON can be controlled by momentary normally closed and normally open contacts respectively. See Figure 3.4 on page 13 for the recommended interface.
- **EXTERNAL INHIBIT:** Allows the user to inhibit the power supply output without switching HIGH VOLTAGE OFF control. This circuit can be used to generate fast slewing output waveforms or control of high voltage generation as in Laser and Capacitor discharge applications. The maximum inhibit rate should not exceed 5Hz. Consult the factory for higher repetition rates or high pulse load applications. See Figure 3.5 on 14 for the recommended interface circuit.

**WARNING**

**IT IS EXTREMELY DANGEROUS TO USE THIS INHIBIT CIRCUIT TO INHIBIT HIGH VOLTAGE GENERATION FOR THE PURPOSE OF SERVICING OR APPROACHING ANY AREA OR LOAD CONSIDERED UNSAFE DURING NORMAL USE.**

- **EXTERNAL INTERLOCK:** Interlock connections are provided on JB4-3 and JB4-4 on the rear of the chassis for connection to a safety switch. The unit will not operate unless the interlock circuit is closed. If the interlock is not being used, the jumper installed on the terminals before shipping must be in place. If the jumper is missing, or there is an opening between

the interlock terminals, the unit's high voltage inverter will be disabled. During high voltage operation, revert to the HIGH VOLTAGE OFF mode. Subsequent closing of the interlock circuit will NOT return the unit to the HIGH VOLTAGE ON mode. This must be accomplished by depressing the HIGH VOLTAGE ON switch. See Figure 3.6 on page 14 for the recommended interface circuit

- **ARC DETECT / ARC QUENCH / ARC COUNT:** The ARC DETECT circuit senses dynamic arcing or discharge conditions present at the output load. If an arc occurs, the output is inhibited for one second. After the one second period, the output is ramped up to the previous set level. This ramp is based on the standard six second slow start feature. The ARC DETECT ramp circuit may be disabled by removing CR32 on the Control/Power Pwb. Caution should be observed if this feature is disabled. Discharge rates of greater than 1Hz may cause excessive power dissipation in the power supply's output limiting resistors.

The ARC COUNT feature will allow the user to program the ARC fault parameters. The ARC indicator on the front panel will illuminate for approximately one second after each arc has occurred. The power supply can be programmed to trip the POWER DOWN mode if an arc occurs.

The standard feature is programmed to trip the power supply if 8 arcs occur within a twenty second period.

- **REMOTE HIGH VOLTAGE ON & REMOTE HIGH VOLTAGE OFF:** Signals are provided for remote monitoring of the HIGH VOLTAGE ON/OFF status. See Figure 3.7 on page 15 for recommended interface.
- **REMOTE MODE INDICATORS:** Signals are provided for remote indication of the control mode status, voltage control, current control, and power control. See Figure 3.8 on page 16 for the recommended interface.

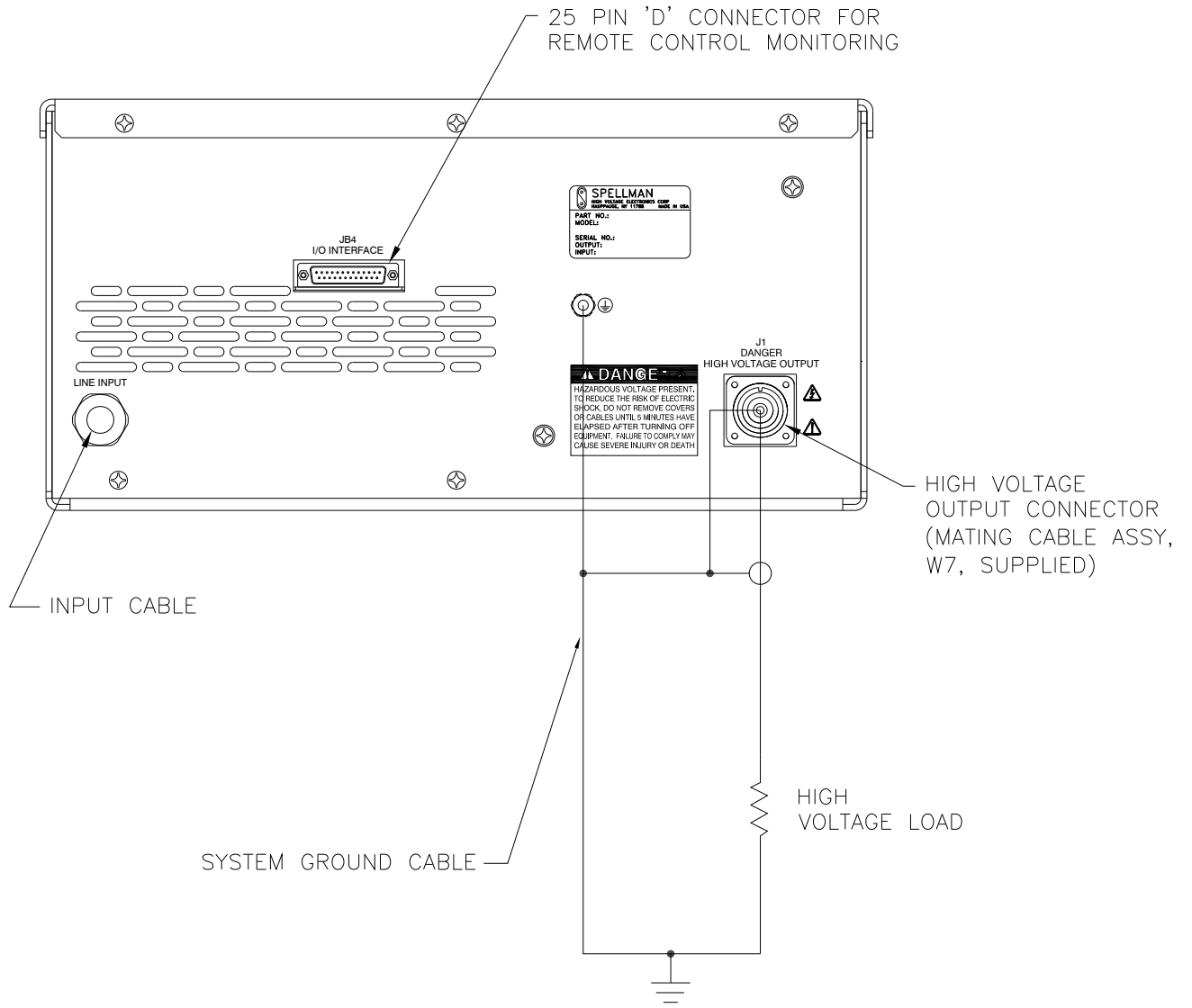

Figure 3.1 Typical Operating Setup

	<b>JB4</b>	<b>SIGNAL</b>	<b>SIGNAL PARAMETERS</b>
	1	Power Supply Common	Signal Ground
	2	External Inhibit	Ground = Inhibit, Open = HV ON
<input type="checkbox"/>	3	External Interlock	+15V at Open, <15mA at Closed
<input type="checkbox"/>	4	External Interlock Return	Return For Interlock
	5	Current Monitor	0 to 10V = 0 to 100% Rated Output
	6	kV Test Point	0 to 10V = 0 to 100% Rated Output
	7	+10V Reference	+10.24V, 1mA Max
<input type="checkbox"/>	8	Remote Current Program In	0 to 10V = 0 to 100% Rated Output
<input type="checkbox"/>	9	Local Current Program Out	Front Panel Program Voltage
<input type="checkbox"/>	10	Remote Voltage Program In	0 to 10V = 0 to 100% Rated Output
<input type="checkbox"/>	11	Local Voltage Program Out	Front Panel Program Voltage
	12	EFR (Common) Power Monitor	Optional External Fault Relay 0-10V = 0-100% Rated Power (Optional)
	13	EFR (Normally Open) Remote Power Program In – Optional	
	14	Local HV Off Out	+15V at Open, < 25mA at Closed. Connect to HV OFF For FP Operation
<input type="checkbox"/>	15	HV OFF	
	16	Remote HV ON	+15V, 10mA Max = HV ON
	17	Remote HV OFF Indicator	0 = HV ON, +15V, 10mA Max = HV OFF
	18	Remote HV ON Indicator	0 = HV OFF, +15V, 10mA Max = HV ON
	19	Remote Voltage Mode	
	20	Remote Current Mode	Open Collector 50V Max, 10mA Max On = Active
	21	Remote Power Mode	
	22	Remote PS Fault	0 = Fault, +15V, 0.1 Ma Max = No Fault
	23	+15V Output	+15V, 100mA Max
	24	Power Supply Common	Signal Ground
	25	Shield Return	Chassis Ground

**Table 3.1 - Rear Panel Interface 25 pin Mini D**

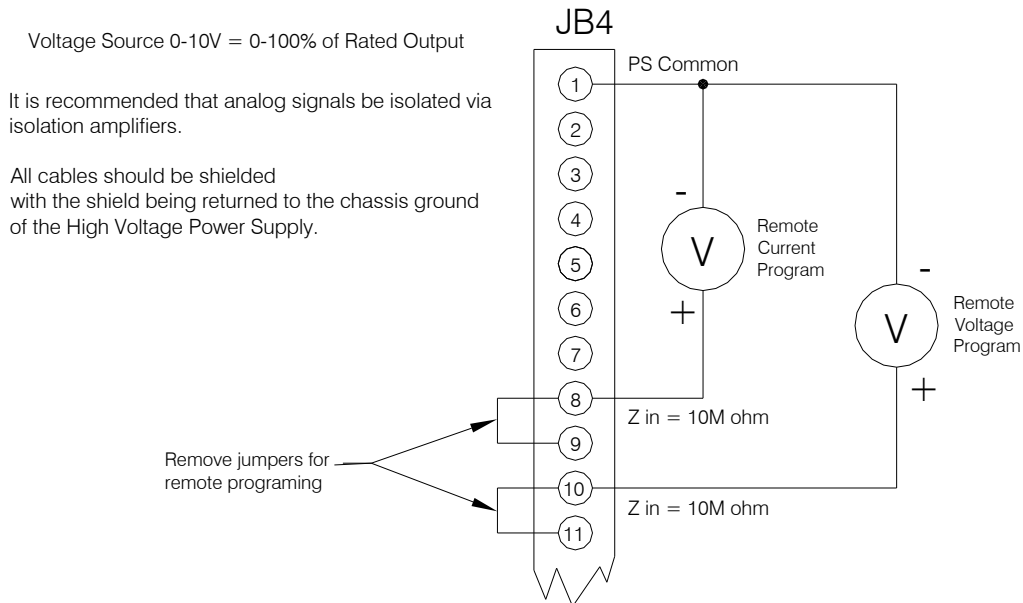

Figure 3.2A -- Wiring Diagram For Remote Programming Via Voltage

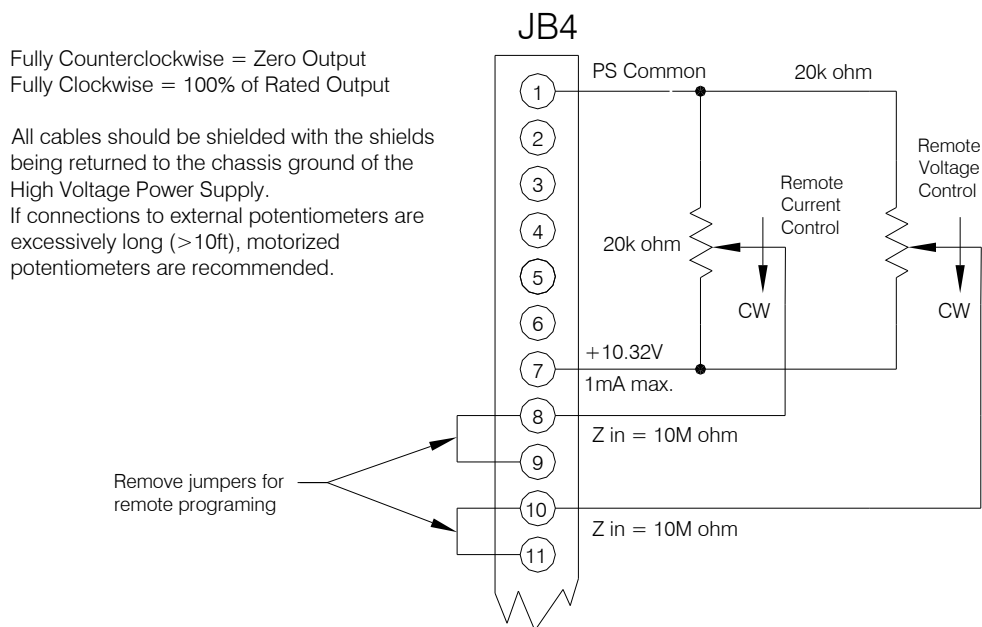
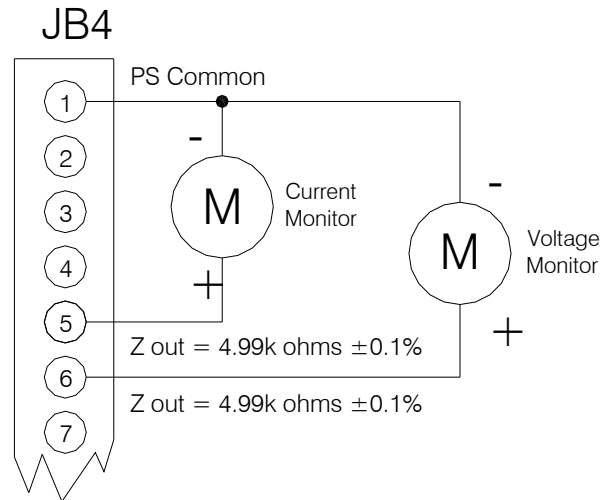

Figure 3.2B -- Wiring Diagram For Remote Programming Via External

It is recommended that analog signals be isolated via isolation amplifiers.

All cables should be shielded with the shield being returned to the chassis ground of the high voltage power supply.



**Figure 3.3 -- Remote Monitor Test Point Designations**

S1 must be closed to enable HIGH VOLTAGE.  
 Momentary closure of S2 will enable HIGH VOLTAGE ON.  
 Opening S1 will disable HIGH VOLTAGE ON and switch the unit to the HIGH VOLTAGE OFF mode.

It is recommended to use relay contacts for S1 and S2. Relays should be located as close as possible to the high voltage power supply. Coils should be driven from isolated sources. Signals are at 15Vdc, 25mA max., and are only to be used for contact closure.

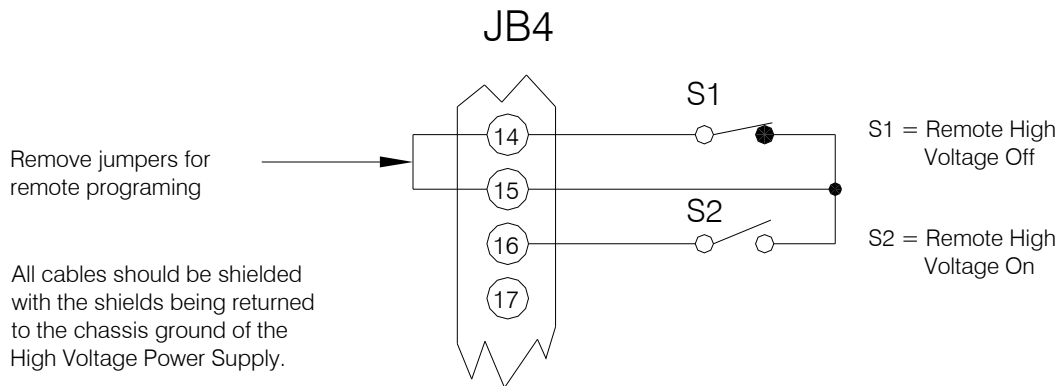

**Figure 3.4 -- Remote Control Of High Voltage On and High Voltage Off**

The transistor should be located as close as possible to the power supply  
 All cables should be shielded with the shields being returned to the chassis ground of the High Voltage Power Supply.

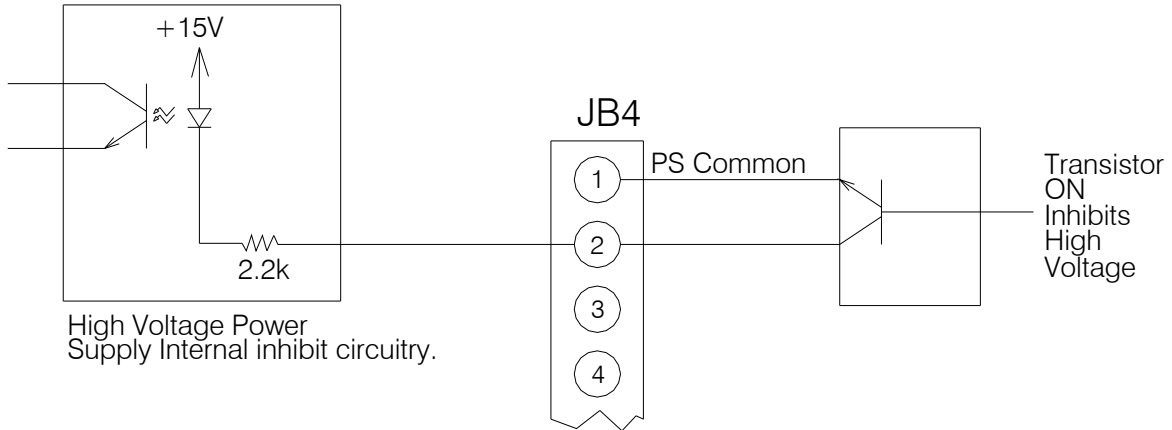
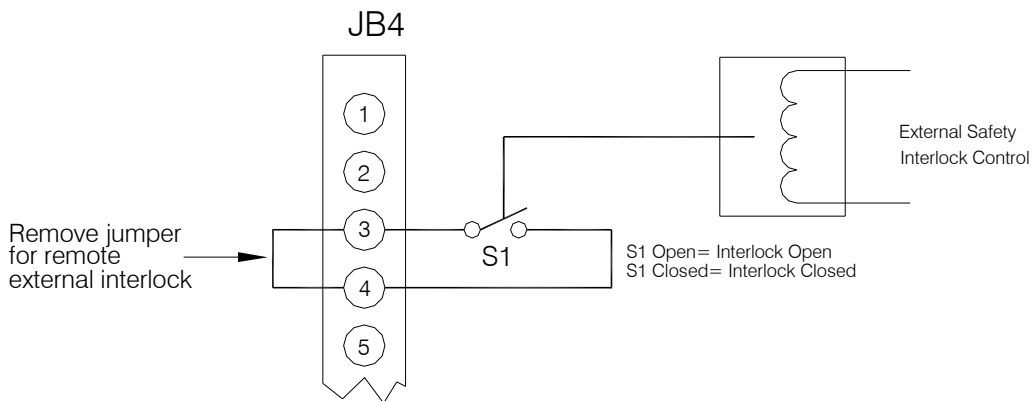

Figure 3.5 -- External Inhibit Interface Circuit

Relay contacts are recommended for S1. The relay should be located as close as possible to the power supply.  
 Signals are at 15Vdc, 25mA max and are only to be used for contact closure.



All cables should be shielded with the shields being returned to the chassis ground of the High Voltage Power Supply.

Figure 3.6 -- External Interlock Interface

12Vdc lamps or relay coils may replace opto-couplers.  
 Opto-couplers, lamps or relays should be located as close  
 as possible to the high voltage power supply.  
 All cables should be shielded with the shields being returned  
 to the chassis ground of the High Voltage Power Supply.

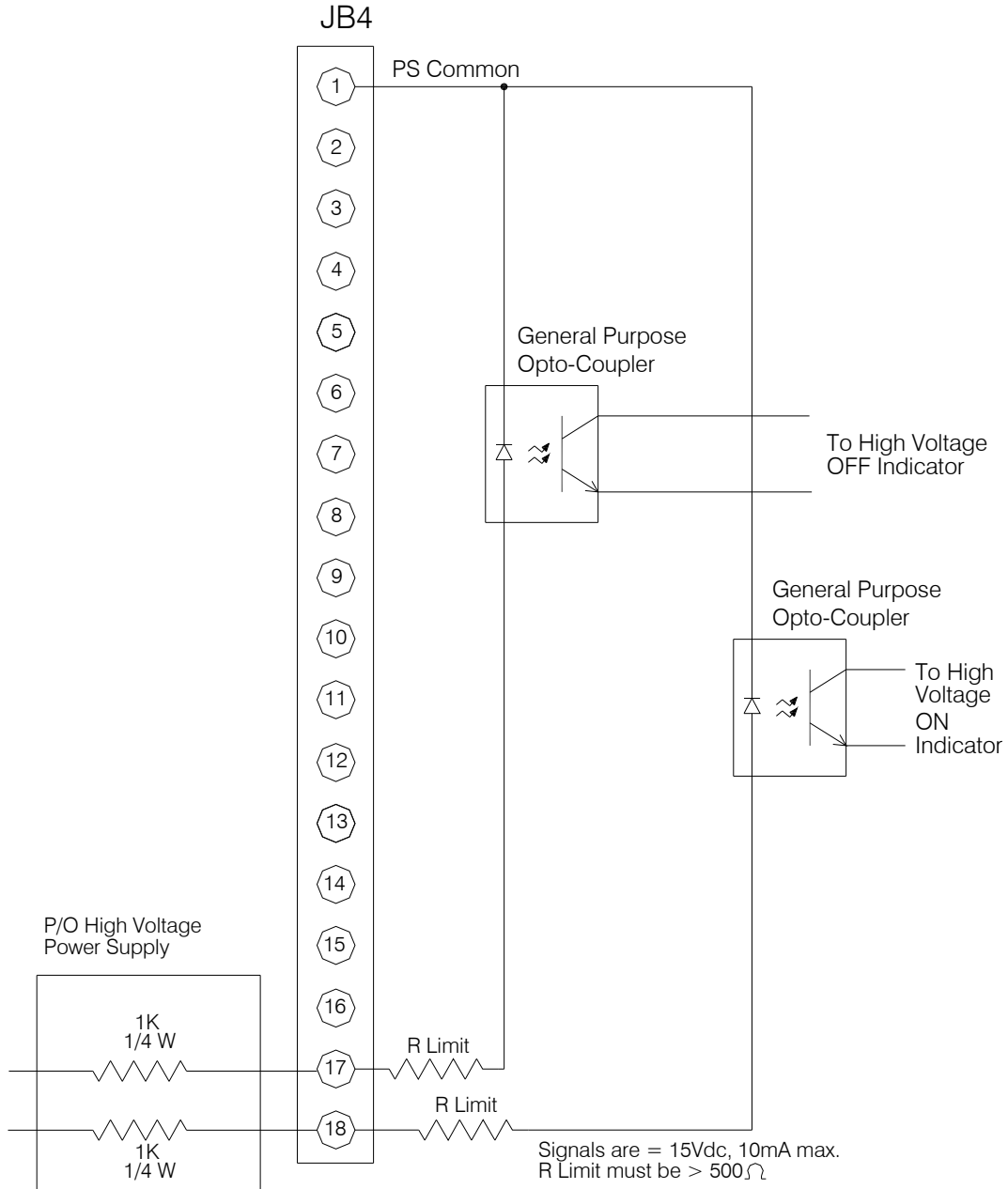

**Figure 3.7 -- Remote High Voltage On and Remote High Voltage Off Indicator**

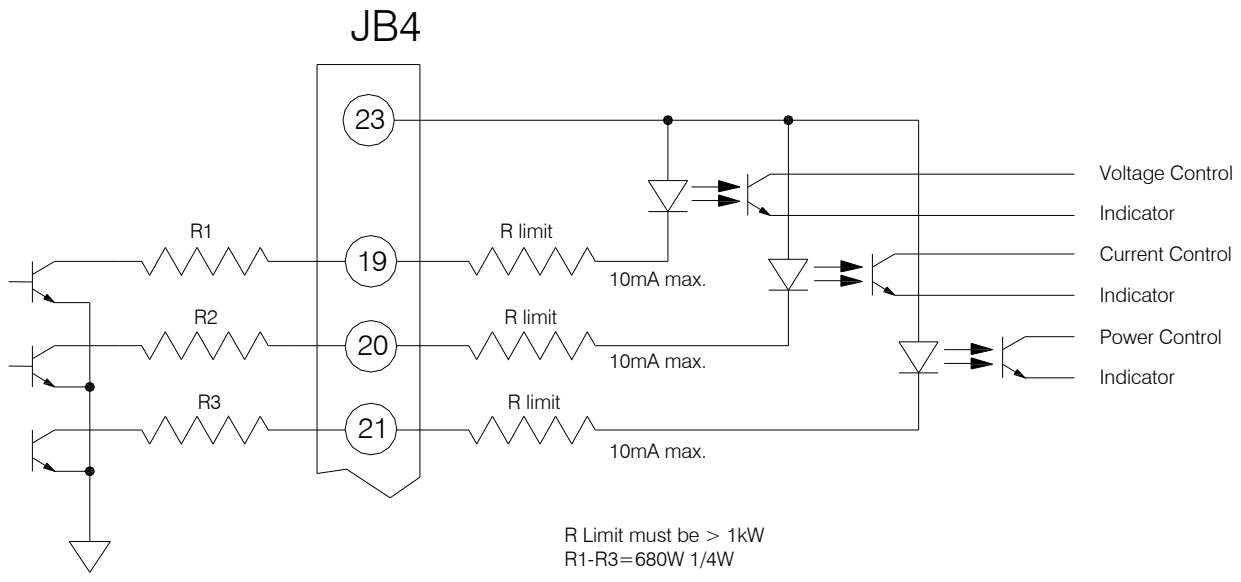

Figure 3.8 -- Remote Mode Indicators Interface

# Chapter 4

## PRINCIPLES OF OPERATION

The SL150 high voltage power supply utilizes sophisticated power conversion technology. A variety of analog, digital and power conversion techniques are used throughout. The intention of the Principles of Operation is to introduce the basic function blocks that comprise the SL power supply. For details on a specific circuit, consult Spellman's Engineering Department.

- Due to the many variations within the SL Series, drawing numbers may differ from unit to unit.

The SL power supply is basically an AC to DC power converter. Within the power supply, conversions of AC to DC then to high frequency AC, then to high voltage DC take place. By reviewing further the sub-assemblies, a basic understanding of the process can be gained.

### 4.1 Chassis

The SL is a compact, high efficiency, high voltage power supply. The power supply can supply up to 1200 watts of DC power.

### WARNING

**The energy levels used and generated by the power supply can be lethal! Do not attempt to operate the power supply unless the user has a sufficient knowledge of the dangers and hazards of working with high voltage. Do not attempt to approach or touch any internal or external circuits or components that are connected or have been connected to the power supply. Be certain to discharge any stored energy that may be present before and after the power supply is used. Consult IEEE recommended practices for safety in high voltage testing #510-1983.**

## 4.2 High Voltage Transformer

The output of the High Frequency Resonant Inverter is connected to the primary of the High Voltage Transformer. The High Voltage Transformer is a set up type.

## 4.3 High Voltage Assembly

The High Voltage Assembly typically consists of various parallel, series arrangements of a full wave voltage doubler.

Output filtering is typically provided by an R-C type filter. Voltage feedback for regulation and monitoring is provided by a high bandwidth resistive/capacitive divider. Current feedback for regulation and monitoring is provided by a sense resistor connected at the low voltage end of the High Voltage Rectifier/Multiplier Circuit.

## 4.4 Control/Power PWB

The majority of control circuits for power supply controls are located on the CONTROL/POWER PWB. +15VDC, -15VDC, and +10VDC is generated on the CONTROL/POWER PWB. High Voltage On/Off control is accomplished by K3, and its associated circuitry. Interlock control is provided by K4.

Voltage feedback from the high voltage divider is sent to the control board via a mass terminated ribbon cable. Gain adjustment is provided on the HV PWB. The kV feedback signal is sent to the front panel DVM and to the REAR PANEL D- CONNECTOR for remote monitoring. K2 provides switching between feedback and program signal for the front panel DVM's. This allows the user to preset the desired output before energizing high voltage.

Program voltages are typically ramped up to set level by a slow start circuit.

An arc sense circuit provides sensing, quench and indicator of arc conditions. Consult the operation manual for a detailed description of the arc sense control.

Current feedback from the high voltage rectifier is sent to sense resistors located on the High Voltage Assembly. Calibrated feedback is then sent to the applicable circuitry on the Control/Power Board.

U12 circuit provides visual indication of the control mode, which is in operation. These signals are sent to the FRONT PANEL ASSEMBLY for front panel status indication.

The resonant control circuitry consists of a pulse width converter. U17 generates all frequency and pulse width control signals.

Power supply inhibit circuits are provided by U22 and K3. System Fault control and Indication is provided by U19 and associated circuitry. Diagnostic signals are latched and then sent to the FRONT PANEL ASSEMBLY for status indication.

## 4.5 Front Panel Assembly

Front Panel controls, meters and status indications are connected to the FRONT PANEL PWB. The FRONT PANEL PWB interfaces directly to the CONTROL/POWER PWB.

## 4.6 Options

Due to the many variations of models and options provided in the SL150, details of actual circuits used may differ slightly from the above descriptions. Consult Spellman's Engineering Department for questions regarding the principles of operation for the SL Series.

# Chapter 5

## OPTIONS

The options available for this power supply are described in this section. Interface diagrams are shown where required. Options are specified by including the option code in the model number as described in Section 1.5.

### 5.1 Adjustable Overload Trip --AOL

The overload trip protection feature rapidly shuts down the high voltage output when the current exceeds the limit set by the current control dial on the front panel. A fast acting circuit inhibits the generation of high voltage and reverts the unit to POWER DOWN mode, illuminating the OVER CURRENT indicator. When adjustable overload trip is provided, it replaces the standard current regulation feature.

### 5.2 200Vac Single Phase Input--200

SL Series power supplies with the 200Vac input option will operate from an input voltage of 200Vac RMS  $\pm 10\%$ , 50 to 60Hz, single phase.

### 5.3 No Slow Start--NSS

The no slow start option causes the output voltage of the power supply to rise (within 50 msec) to the rated voltage upon depressing the HIGH VOLTAGE ON switch.

### 5.4 Non-Standard Slow Start--SS(x)

The non-standard slow start option allows the gradual rise time of the output voltage to be different from the standard of six seconds. To order the option place the time desired in seconds after the suffix letter, i.e. SS (10) denotes a 10 second rise time.

### 5.5 Extra Length Output Cable--LL(ft)

Standard output cable is 10 feet of shielded high voltage cable. Other lengths may be specified in multiples of 10 feet.

### 5.6 Arc Trip Option--AT

When this option is ordered, the Arc Count circuit is set so the unit trips to Standby after 1 count. One of the applications for this option is for sensing a material breakdown under an applied high voltage.

### 5.7 Reversible Polarity Option--PN

### 5.8 Adjustable Power Trip/Constant Power Control

#### APT/CPC Option

The power control options allow monitoring and control of the power supply output power. The APT option allows the user to remotely adjust the power limit for the power supply. If the power limit is exceeded, the unit will shut down with an OVERPOWER fault. The CPC option allows power regulation via an internal preset potentiometer, or a remote program source. When the unit is in power regulation, the POWER CONTROL status indicator will be illuminated. See Figure 5.1 for remote interface.

## 5.9 External Fault Relay Option EFR

The external fault relay option provides a set of customer accessible relay contacts that are controlled by the fault status circuitry of the applicable SL Series power supply. A standard SL power supply will revert to the “power down” mode with a visual front panel indication if any of the following fault conditions occur:

- **Overvoltage:** Greater than 110% of maximum output voltage was produced by the power supply.
- **Overcurrent:** Greater than 104% of maximum output current was produced by the power supply or the AOL circuitry was activated.
- **Overtemperature:** Excessive temperature has been sensed within the chassis.
- **Regulation Error:** Lack of required output power to maintain regulation
- **Arc (Shutdown):** Arc sensing circuit has shut down the supply due to excessive arcing.
- **Overpower:** The power supply has exceeded the internally set power limit level, if such circuitry is installed.

With the installation of the EFR option, if any of these faults occur, a relay will be activated to provide a remote indication that the power supply has reverted to the “power down” mode. The common, normally open and normally closed set of contacts are provided. Relay contacts are rated at 1A at 30Vdc or 0.5A at 48Vac.

Connections on JB4 can be made as follows:

- |          |                 |
|----------|-----------------|
| (JB4-12) | Relay Common    |
| (JB4-NA) | Normally Closed |
| (JB4-13) | Normally Open   |

Resetting the front panel and EFR relay is accomplished by depressing the green front panel HV OFF push-button switch, which reverts the power supply back to the “standby” mode. Removal and reapplication of the AC line input voltage will also reset any fault.

The circuitry and components required for the EFR option are installed at the factory when this option is ordered.

## 5.10 No ARC Detect Option NAD

The No ARC Detect option may be utilized by removing CR32 on the control board. Caution should be observed if this feature is disabled. Discharge rates of greater than 1Hz may cause excessive power dissipation in the power supply’s output limiting resistors.

## 5.11 Remote Fault Reset Option RFR

Allows the user to remotely reset a fault by momentarily grounding JB4-12.

## 5.12 Custom Designed Models-X#

Units built to customer specification are assigned an X number by the factory. If this unit is an X model, a specification control sheet is added at the end of the test of this instruction manual.

Spellman welcomes the opportunity to customize units to fit your requirements or to develop new products for your applications. Contact the Spellman Sales Department with your needs.

Remove internal jumper, JP1 ON Control/Pwr PWB for remote Programing. (Jumper connects internal, pot, factory set at 103% of max power).

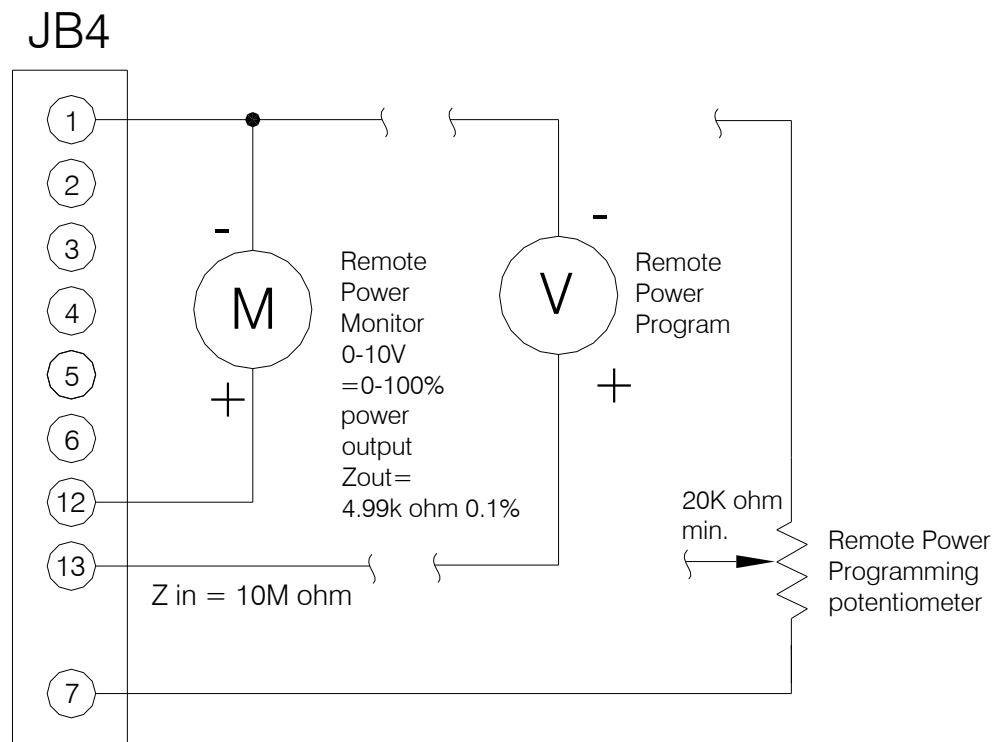
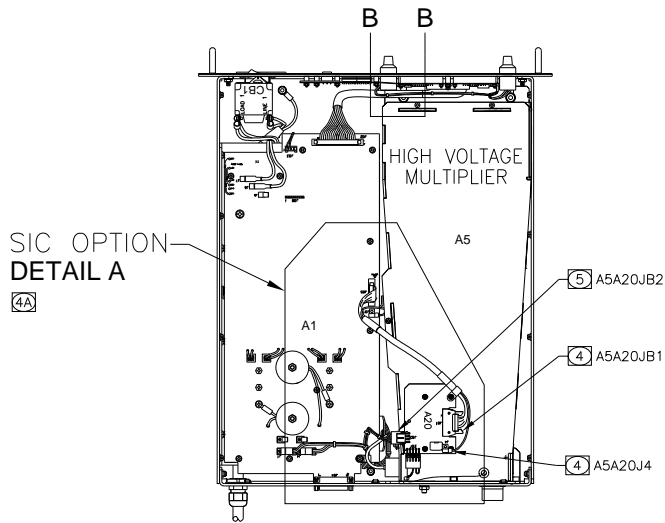
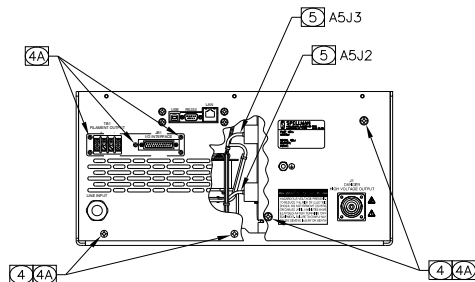

Figure 5.1 Adjustable Power Remote Interface Option



SIC OPTION  
DETAIL A

4A



REAR VIEW  
SHOWN WITH SIC OPTION

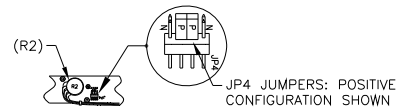
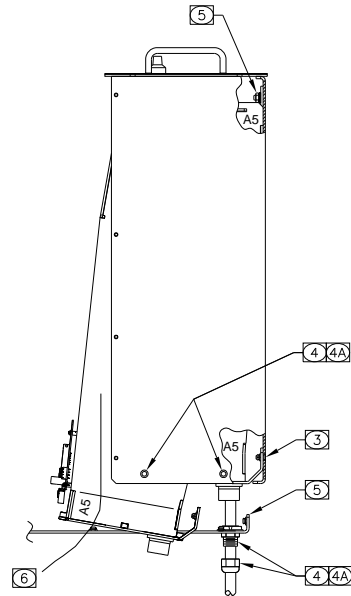

VIEW B-B

NOTE: JP4 NOT USED ON SUPPLIES  
EQUIPPED WITH BLANK FRONT PANELS

7

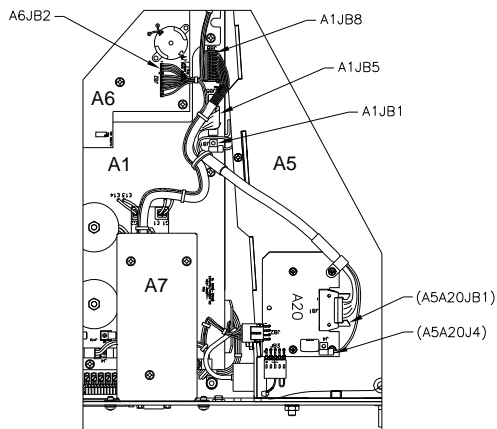

DETAIL A  
SIC OPTION

4A

- 1 TURN UNIT OFF. UNPLUG LINE CORD FROM AC OUTLET AND WAIT 5 MINUTES BEFORE PROCEEDING TO CHANGE THE HIGH VOLTAGE MULTIPLIER.
- 2 REMOVE COVER BY REMOVING THE 11 SCREWS FROM THE CHASSIS (8) AND REAR PANEL(3).
- 3 ROTATE POWER SUPPLY ON TO ITS SIDE, WITH THE MULTIPLIER ON THE BOTTOM. CAUTION: DO NOT ALLOW POWER SUPPLY TO REST ON THE EDGE OF THE FRONT PANEL. REMOVE THE 2 BOTTOM SCREWS AT THE REAR EDGE OF CHASSIS. RESTORE POWER SUPPLY TO ITS NORMAL POSITION.
- 4 TOTALLY UNSCREW CLAMP NUT ON LINE CORD. REMOVE THE 6 REAR PANEL SCREWS (2 ON EACH SIDE, 2 ON BOTTOM EDGE). REMOVE THE 2 MULTIPLIER SCREWS. UNPLUG A5A20JB1 AND A5A20J4.
- 4A IF UNIT IS EQUIPPED WITH THE SIC OPTION: COMPLETE STEP 4. REMOVE THE 5 CONNECTOR PLATE SCREWS AT TB1/JB1. UNPLUG A1JB8, A1JB5, A1JB1, AND A6JB2.
- 5 PULL REAR PANEL STRAIGHT BACK AND ROTATE 90°. UNPLUG A5A20JB2, A5J2, AND A5J3. REMOVE THE 2 NUTS AND WASHERS AT THE FRONT END OF THE MULTIPLIER. CAUTION: USE CARE WITH REMOVAL/REPLACEMENT TOOL WHILE WORKING NEAR THE FRONT PANEL PRINTED WIRING BOARD AND COMPONENTS.
- 6 LIFT REAR OF MULTIPLIER AND SLIDE OUT A FEW INCHES. CAREFULLY LIFT MULTIPLIER UP AND OUT OF CHASSIS.
- 7 CHANGE POSITION OF JP4 JUMPERS ON FRONT PANEL TO MATCH POLARITY OF UNIT, i.e., 2 JUMPERS MUST BE ON "N" POSITIONS FOR NEGATIVE UNITS, OR ON "P" POSITIONS FOR POSITIVE UNITS.
- 8 INSTALL NEW MULTIPLIER BY FOLLOWING STEPS 2-6 IN REVERSE.

Figure 5.2 Reverse Polarity Option

# Chapter 6

## MAINTENANCE

This section describes periodic servicing and performance testing procedures.

### WARNING

**THIS POWER SUPPLY GENERATES VOLTAGES THAT ARE DANGEROUS AND MAY BE FATAL. OBSERVE EXTREME CAUTION WHEN WORKING WITH HIGH VOLTAGE.**

### 6.1 Periodic Servicing

Approximately once a year (more often in high dust environments), disconnect the power to the unit and remove the top cover. Use compressed air to blow dust out of the inside of the unit. Avoid touching or handling the high voltage assembly. Be sure that the fan is not obstructed and spins freely. The fan has sealed bearings and does not need lubrication. Be sure to replace the top cover before operating for proper cooling.

### 6.2 Performance Test

#### WARNING

**HIGH VOLTAGE IS DANGEROUS.**

**ONLY QUALIFIED PERSONNEL SHOULD PERFORM THESE TESTS.**

High voltage test procedures are described in Bulletin STP-783, Standard Test Procedures for High Voltage Power Supplies. Copies can be obtained from the Spellman Customer Service Department. Test equipment, including an oscilloscope, a high impedance voltmeter, and a high voltage divider such as the Spellman HVD-200 is needed for performance tests. All test components must be rated for operating voltage.

### 6.3 High Voltage Dividers

High voltage dividers for precise measurements of output voltage with an accuracy up to 0.1% are available. An HVD-200 measures up to 200kV. The Spellman divider is designed for use with differential voltmeters or high impedance digital voltmeters. The high input impedance is ideal for measuring high voltage low current sources, which would be overloaded by traditional lower impedance dividers.

# Chapter 7

## REPLACEMENT PARTS

### 7.1 Replacement Parts

Contact the Spellman Customer Service Department for parts lists for specific models.

Parts and subassemblies for Spellman's high voltage power supplies are available. It is recommended that only qualified personnel perform the repairs. High voltage is dangerous; even minor mistakes in repairs can have serious consequences.

When requesting parts please give the model number and serial number of the power supply.

### 7.2 Correspondence and Ordering Spare Parts

Each power supply has an identification label on the rear of the chassis that bears its model and serial number.

When requesting engineering or applications information, please state the model and serial number of the power supply.

When ordering spare parts, please specify the part number, the component function and the model and serial number of the unit.

# Chapter 8

## FACTORY SERVICE

### 8.1 Warranty Repairs

During the Warranty period, Spellman will repair all units free of charge. The Warranty is void if the unit is worked on by other than Spellman personnel. See the Warranty in the rear of this manual for more information. Follow the return procedures described in Section 8.2. The customer shall pay for shipping to and from Spellman.

### 8.2 Factory Service Procedures

Spellman has a well-equipped factory repair department. If a unit is returned to the factory for calibration or repair, a detailed description of the specific problem should be attached.

For all units returned for repair, please obtain an authorization to ship from the Customer Service Department, either by phone or mail prior to shipping. When you call, please state the model and serial numbers, which are on the plate on the rear of the power supply, and the purchase order number for the repair. A Return Material Authorization Code Number (RMA Number) is needed for all returns. This RMA Number should be marked clearly on the outside of the shipping container. Packages received without an RMA Number will be returned to the customer. The Customer shall pay for shipping to and from Spellman.

A preliminary estimate for repairs will be given by phone by Customer Service. A purchase order for this amount is requested upon issuance of the RMA Number. A more detailed estimate will be made when the power supply is received at the Spellman Repair Center. In the event that repair work is extensive, Spellman will call to seek additional authorization from your company before completing the repairs.

### 8.3 Ordering Options and Modifications

Many of the options listed in Chapter 5 can be retrofitted into Spellman's power supplies by our factory. For prices and arrangements, contact the Spellman Sales Department.

### 8.4 Shipping Instructions

All power supplies returned to Spellman must be sent shipping prepaid. Pack the units carefully and securely in a suitable container, preferably in the original container, if available. The power supply should be surrounded by at least four inches of shock absorbing material. Please return all associated materials, i.e. high voltage output cables, interconnection cables, etc., so that we can examine and test the entire system.

All correspondence and phone calls should be directed to:

**Spellman High Voltage Electronics Corp.**  
475 Wireless Boulevard  
Hauppauge, New York 11788  
TEL: (631) 630-3000 FAX: (631) 435-1620  
E-Mail: [sales@Spellmanhv.com](mailto:sales@Spellmanhv.com)

# WICHTIGE SICHERHEITSHINWEISE

## SICHERHEIT

DIESES HOCHSPANNUNGSNETZTEIL ERZEUGT LEBENSGEFÄHRLICHE HOCHSPANNUNG.  
SEIN SIE SEHR VORSICHTIG BEI DER ARBEIT MIT DIESEM GERÄT.

Das Hochspannungsnetzteil muß immer geerdet sein.

Berühren Sie die Stecker des Netzteiles nur, wenn das Gerät ausgeschaltet ist und die elektrischen Kapazitäten des Netzteiles und der angeschlossenen Last entladen sind.

Die internen Kapazitäten des Hochspannungsnetzteiles benötigen ca. 5 Minuten, um sich zu entladen.

Erden Sie sich nicht, und arbeiten Sie nicht in feuchter oder nasser Umgebung.

## SERVICESICHERHEIT

Notwendige Reparaturen können es erforderlich machen, den Gehäusedeckel während des Betriebes zu entfernen.

Reparaturen dürfen nur von qualifiziertem, eingewiesenem Personal ausgeführt werden.

“WARNING” im folgenden Text weist auf gefährliche Operationen hin, die zu Verletzungen oder zum Tod führen können.

“CAUTION” im folgenden Text weist auf Prozeduren hin, die genauestens befolgt werden müssen, um eventuelle Beschädigungen des Gerätes zu vermeiden.

# PRECAUTIONS IMPORTANTES POUR VOTRE SECURITE

## CONSIGNES DE SÉCURITÉ

CETTE ALIMENTATION GÉNÈRE DES TENSIONS QUI SONT DANGEUREUSES ET PEUVENT ÊTRE FATALES.  
SOYEZ EXTRÊMEMENT VIGILANTS LORSQUE VOUS UTILISEZ CET ÉQUIPEMENT.

Les alimentations haute tension doivent toujours être mises à la masse.

Ne touchez pas les connectiques sans que l'équipement soit éteint et que la capacité à la fois de la charge et de l'alimentation soient déchargées.

Prévoyez 5 minutes pour la décharge de la capacité interne de l'alimentation.

Ne vous mettez pas à la masse, ou ne travaillez pas sous conditions mouillées ou humides.

## CONSIGNES DE SÉCURITÉ EN CAS DE REPARATION

La maintenance peut nécessiter l'enlèvement du couvercle lorsque l'alimentation est encore allumée.

Les réparations doivent être effectuées par une personne qualifiée et connaissant les risques électriques.

Dans le manuel, les notes marquées « **WARNING** » attire l'attention sur les risques lors de la manipulation de ces équipements, qui peuvent entraîner de possibles blessures voire la mort.

Dans le manuel, les notes marquées « **CAUTION** » indiquent les procédures qui doivent être suivies afin d'éviter d'éventuels dommages sur l'équipement.

## IMPORTANTI PRECAUZIONI DI SICUREZZA

### SICUREZZA

QUESTO ALIMENTATORE GENERA TENSIONI CHE SONO PERICOLOSE E POTREBBERO ESSERE MORTALI.  
PONI ESTREMA CAUTELA QUANDO OPERI CON QUESTO APPARECCHIO.

- Gli alimentatori ad alta tensione devono sempre essere collegati ad un impianto di terra.
- Non toccare le connessioni a meno che l'apparecchio sia stato spento e la capacità interna del carico e dell'alimentatore stesso siano scariche.
- Attendere cinque minuti per permettere la scarica della capacità interna dell'alimentatore ad alta tensione.
- Non mettere a terra il proprio corpo oppure operare in ambienti bagnati o saturi d'umidità.

### SICUREZZA NELLA MANUTENZIONE.

- Manutenzione potrebbe essere richiesta, rimuovendo la copertura con apparecchio acceso.
- La manutenzione deve essere svolta da personale qualificato, coscio dei rischi elettrici.
- Attenzione alle **AVVERTENZE** contenute nel manuale, che richiamano all'attenzione ai rischi quando si opera con tali unità e che potrebbero causare possibili ferite o morte.
- Le note di **CAUTELA** contenute nel manuale, indicano le procedure da seguire per evitare possibili danni all'apparecchio.

# SPELLMAN HIGH VOLTAGE ELECTRONICS

## WARRANTY

**Spellman** High Voltage Electronics ("**Spellman**") warrants that all power supplies it manufactures will be free from defects in materials and factory workmanship, and agrees to repair or replace, without charge, any power supply that under normal use, operating conditions and maintenance reveals during the warranty period a defect in materials or factory workmanship. The warranty period is twelve (12) months from the date of shipment of the power supply. With respect to standard SL power supplies (not customized) the warranty period is thirty-six (36) months from the date of shipment of the power supply.

This warranty does not apply to any power supply that has been:

- Disassembled, altered, tampered, repaired or worked on by persons unauthorized by **Spellman**;
- subjected to misuse, negligent handling, or accident not caused by the power supply;
- installed, connected, adjusted, or used other than in accordance with the original intended application and/or instructions furnished by **Spellman**.

THE FOREGOING WARRANTY IS IN LIEU OF ALL OTHER WARRANTIES, EXPRESS OR IMPLIED, INCLUDING THOSE OF MERCHANTABILITY OR FITNESS FOR A PARTICULAR PURPOSE.

The buyer's sole remedy for a claimed breach of this warranty, and **Spellman's** sole liability is limited, at **Spellman's** discretion, to a refund of the purchase price or the repair or replacement of the power supply at **Spellman's** cost. The buyer will be responsible for shipping charges to and from **Spellman's** plant. The buyer will not be entitled to make claim for, or recover, any anticipatory profits, or incidental, special or consequential damages resulting from, or in any way relating to, an alleged breach of this warranty.

No modification, amendment, supplement, addition, or other variation of this warranty will be binding unless it is set forth in a written instrument signed by an authorized officer of **Spellman**.

### Factory Service Procedures

For an authorization to ship contact **Spellman's** Customer Service Department. Please state the model and serial numbers, which are on the plate on the rear panel of the power supply and the reason for return. A Return Material Authorization Code Number (RMA number) is needed from **Spellman** for all returns. The RMA number should be marked clearly on the outside of the shipping container. Packages received without an RMA Number may delay return of the product. The buyer shall pay shipping costs to and from **Spellman**. Customer Service will provide the Standard Cost for out-of-warranty repairs. A purchase order for this amount is requested upon issuance of the RMA Number (in-warranty returns must also be accompanied by a "zero-value" purchase order). A more detailed estimate may be made when the power supply is received at **Spellman**. In the event that the cost of the actual repair exceeds the estimate, **Spellman** will contact the customer to authorize the repair.

### Factory Service Warranty

**Spellman** will warrant for three (3) months or balance of product warranty, whichever is longer, the repaired assembly/part/unit. If the same problem shall occur within this warranty period **Spellman** shall undertake all the work to rectify the problem with no charge and/or cost to the buyer. Should the cause of the problem be proven to have a source different from the one that has caused the previous problem and/or negligence of the buyer, **Spellman** will be entitled to be paid for the repair.

### Spellman Worldwide Service Centers

For a complete listing of **Spellman's** Global Service facilities please go to:  
<http://www.spellmanhv.com/customerservice/service.asp>