

Instruction Manual

MNX SERIES

High Voltage Power Supply

MODEL :
SERIAL# :
DATE :

**SPELLMAN
HIGH VOLTAGE ELECTRONICS
CORPORATION**

475 Wireless Blvd.
Hauppauge, New York, 11788

+1(631) 630-3000*FAX: +1(631) 435-1620*
E-mail: sales@spellmanhv.com
Website: www.spellmanhv.com

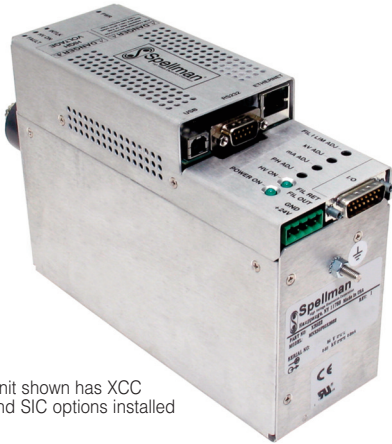

Unit shown has XCC and SIC options installed

- **50KV AT 2 MA. 50 OR 75 WATT MAX.**
- **65KV AT 2 MA. 65 WATT MAX.**
- **ADJUSTABLE INTEGRATED FILAMENT SUPPLY**
- **OVERVOLTAGE & SHORT CIRCUIT PROTECTION**
- **VOLTAGE & CURRENT PROGRAMMING**
- **LOCAL AND REMOTE EMISSION CONTROL**
- **SAFETY INTERLOCK**
- **OEM CUSTOMIZATION AVAILABLE**
- **CE MARKED, UL RECOGNIZED**

www.spellmanhv.com/manuals/MNX

The MNX Series is the result of Spellman's exceptional high voltage packaging and surface mount fabrication techniques, coupled with its proprietary encapsulation technology producing this ultra compact-sized OEM 50 Watt X-ray generator module.

The MNX Series is designed to power grounded cathode X-ray tubes from a variety of well known manufacturers. It features a 0 to 50kV high voltage output, and up to 2mA of emission current limited to 50, 65 or 75 Watts, operating from a +24Vdc input. The MNX utilizes a closed loop filamentary beam control circuit to provide a highly regulated beam current. The ground referenced low noise dc filament supply operates between 0.3 and 3.5 amps. Offering tight regulation, high stability and low ripple, the MNX provides users both local and remote analog control to set beam voltage, emission current and filament current limit. An optional USB, RS-232 or ethernet interface is available.

TYPICAL APPLICATIONS

Powering grounded cathode X-ray tubes from Kevex, Oxford, RTW, Superior, Varian and Trufocus.

OPTIONS

- XCC** XRM Compatible HV Cable (50kV only)
- SIC** Standard Interface Controller (Ethernet, USB & RS-232)
- 5VPM** 0 to 5 Volt Programming and Monitor Scaling
- GB** Grid Bias Option

SPECIFICATIONS

Input:

+24Vdc $\pm 10\%$, 5.0A maximum for either 50 Watts or 75 Watts.
+24Vdc $\pm 1V$, 5.0A maximum for 65kV/65W units.

Efficiency:

80-85%, typical

Output:

0 to 50kV at 0 to 2mA, limited to a maximum of 50 watts or 75 Watts. 0-65kV at 2mA limited to 65 Watts.

Voltage Control:

Local: Internal multi-turn potentiometer to set voltage from 0 to full output voltage.
Remote: 0 to +10Vdc proportional from 0 to full output voltage. Accuracy: $\pm 1\%$. Z_{IN} : 10Mohm.

Emission Control:

Local: Internal potentiometer to set beam current between 0 and full output current.
Remote: 0 to +10Vdc proportional from 0 to full output current. Accuracy : $\pm 1\%$. Z_{IN} : 10Mohm. Filament limit and filament preheat control capability is also provided.

DC Filament Supply:

Current: 3.5A, adjustable limit
Voltage: 5.0 volt limit

Voltage Regulation:

Load: 0.01% of output voltage no load to full load.
Line: $\pm 0.01\%$ for $\pm 10\%$ change in input voltage.

Current Regulation:

Load: 0.01% of output current from 0 to rated voltage.
Line: $\pm 0.01\%$ for $\pm 10\%$ change in input voltage.

Ripple:

0.1% p-p of maximum rated output voltage, 50kV units (50/75W)
0.1% rms maximum rated output voltage, 65kV units (65W)

Environmental:

Operational: 0°C to +50°C
Storage: -40°C to +85°C
Humidity: 0% to 90%, non-condensing

Temperature Coefficient:

0.01% per °C, voltage and current.

Stability:

0.05% per 8 hours after 1/2 hour warm-up.

Voltage and Current Monitors:

0 to +10Vdc proportional from 0 to rated output. Accuracy $\pm 1\%$.

Dimensions:

50kV Unit: 5.00"H x 2.87"W x 8"D
(127.00mm x 72.90mm x 203.25mm).
65kV Unit: 5.00"H x 2.87"W x 9"D
(127.00mm x 72.90mm x 228.65mm).
XCC Option: 5.00"H x 2.87"W x 9"D (50/75W units only)
(127.00mm x 72.90mm x 228.65mm).
SIC Option: 5.75"H x 2.87"W x 8"D
(146.05mm x 72.90mm x 203.25mm).

Weight:

6.5 lbs. (2.9kg)

Regulatory Approvals:

Compliant to 2004/108/EC, the EMC Directive and 2006/95/EC, the Low Voltage Directive. UL/CUL recognized, File E227588.

MNX POWER INPUT CONNECTOR

J2	SIGNAL	PARAMETER
1	+24V Input	+24 volts @ 5A, max.
2	24V Return (Gnd.)	Power Ground

MNX FILAMENT CONNECTOR

J3	SIGNAL	PARAMETER
1	Filament Out	0.3A to 3.5A, 5 volt, max.
2	Filament Return	Filament Ground

ANALOG INTERFACE CONNECTOR MALE 15 PIN MINI "D"

J4	SIGNAL	PARAMETER
1	Monitor Return	Signal Ground
2	Voltage Monitor	0-10 volts = 0 to full scale, Zout=1KΩ
3	Current Monitor	0-10 volts = 0 to full scale, Zout=1KΩ
4	Interlock Output	Connect 12V HVON bulb to pin 15 to enable
5	+10 Volt Reference	+10 Volts at 1mA, maximum
6	Filament Monitor	1 volt = 1 amp, Zout=1KΩ
7	Voltage Program Input	0-10 volts = 0 to full scale, Zin=10MΩ
8	Local Voltage Program*	0-10 volts, screwdriver adjust
9	Filament Limit Setpoint*	1 volt = 1 amp, screwdriver adjust
10	Current Program Input	0-10 volts = 0 to full scale, Zin=10MΩ
11	Local Current Program*	10 turn pot, screwdriver adjust
12	Not used (+24V Out for Interlock)	(Optional Interlock configuration)
13	Not used (Interlock Coil)	(Optional Interlock configuration)
14	Filament Preheat Setpoint*	1 volt = 1 amp, screwdriver adjust
15	Interlock Return	Interlock Ground

*Denotes 10 turn potentiometer located on front panel

MNX HIGH VOLTAGE OUTPUT CONNECTOR

J1

Spellman designed drywell type detachable connector. A one meter (39.4") long mating high voltage cable is provided.

GRID BIAS CONNECTOR 2 PIN PHOENIX CONTACT

J5	SIGNAL	PARAMETER
1	Ground	Chassis Ground
2	Grid Bias	0 to -300Vdc

How To Order:

Sample model number:

50 Watt unit: MNX50P50

65 Watt unit: MNX65P65

75 Watt unit: MNX50P75

Options are added to the model number as follows:

MNX50P50/XCC or MNX50P75/SIC

Grid Bias Option (GB):

Plug-n-Play compatibility for Oxford's Apogee X-Ray Tube
Spellman's Grid Bias Option for the MNX Series is specifically designed for popular commercially available grid bias X-Ray tubes. The Grid Bias voltage is developed via the use of separate integrated high frequency switching circuit, providing maximum flexibility and control. The Grid Bias output is a voltage regulated, current compliant topology ideally suited for Wehnelt electrode applications. Arc and short circuit protection of the Grid Bias output prevents any damage due to transient events or installation errors.

Tracking Mode Operation

Functioning in tracking mode the voltage monitor (0-10Vdc = 0 to 50kV) of the main high voltage output is internally connected to the Grid Bias programming input (0-10Vdc = 0 to -300Vdc of Grid Bias). Connected in this manner the Grid Bias output will track in a linearly proportional fashion the setting of the main kV output.

A front panel accessible multturn potentiometer limits the maximum magnitude of Grid Bias output applied to the X-Ray tube, providing unparalleled flexibility.

The output of the Grid Bias option is provided via an auxiliary two position Phoenix Contact terminal block, the mating connector is provided.

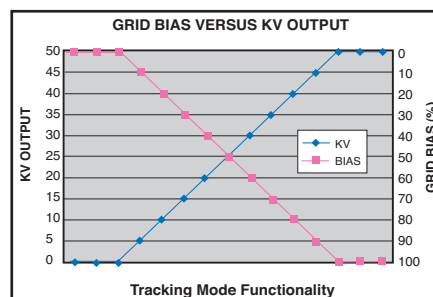

GRID BIAS SPECIFICATIONS

- Output Voltage:** 0 to -300Vdc
- Output Current:** 0.25mA, maximum
- Load Regulation:** 1% of output voltage, no load to full load
- Line Regulation:** 1% for a ±10% change in input voltage
- Ripple:** 1% of maximum rated voltage

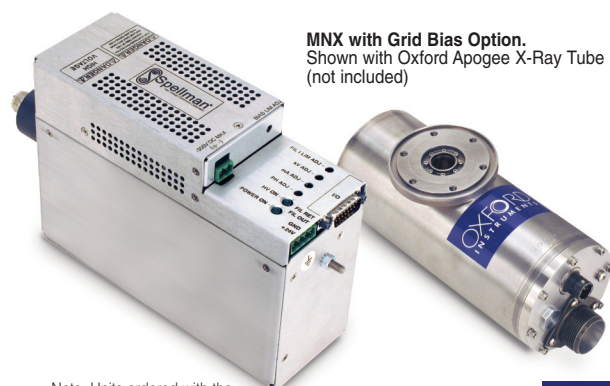

MNX with Grid Bias Option. Shown with Oxford Apogee X-Ray Tube (not included)

Note: Units ordered with the GB Option will be provided with the XCC Option for proper high voltage cable compatibility.



DIMENSIONS: in.[mm]

50KV

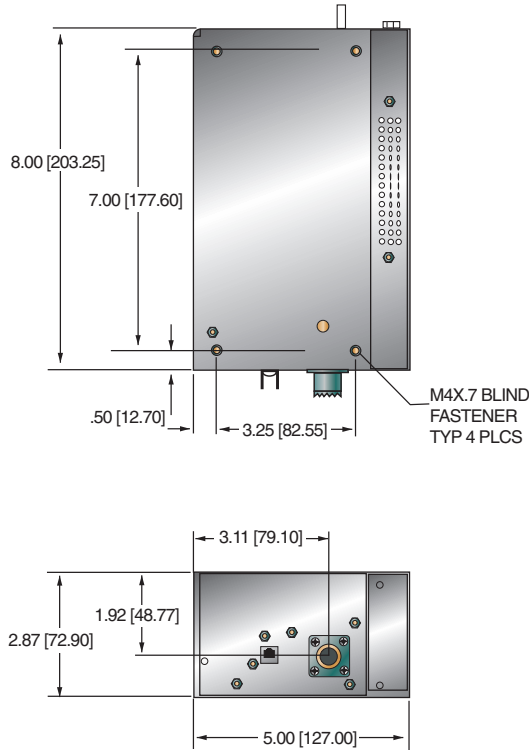

50KV WITH XCC OPTION

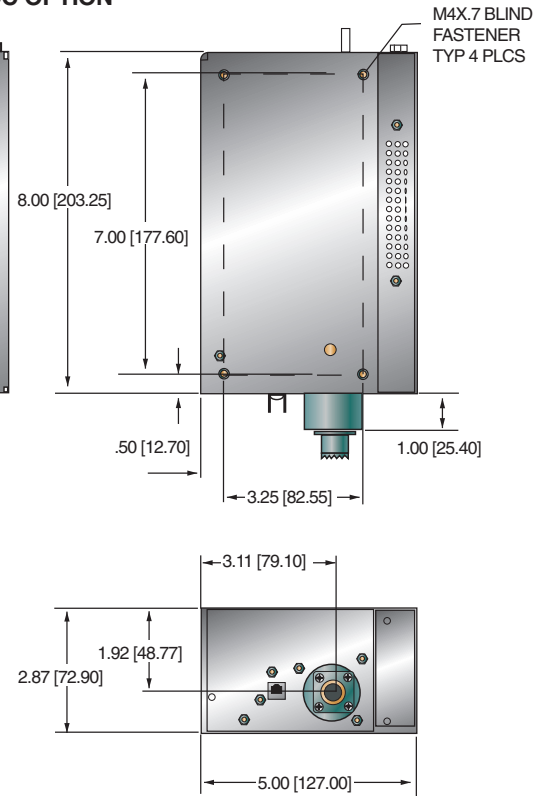

50KV WITH SIC OPTION

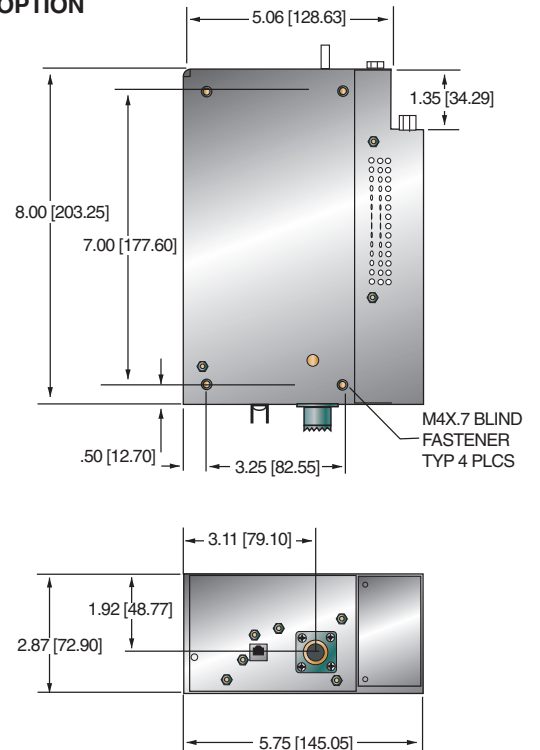

DIMENSIONS: in.[mm]

65KV

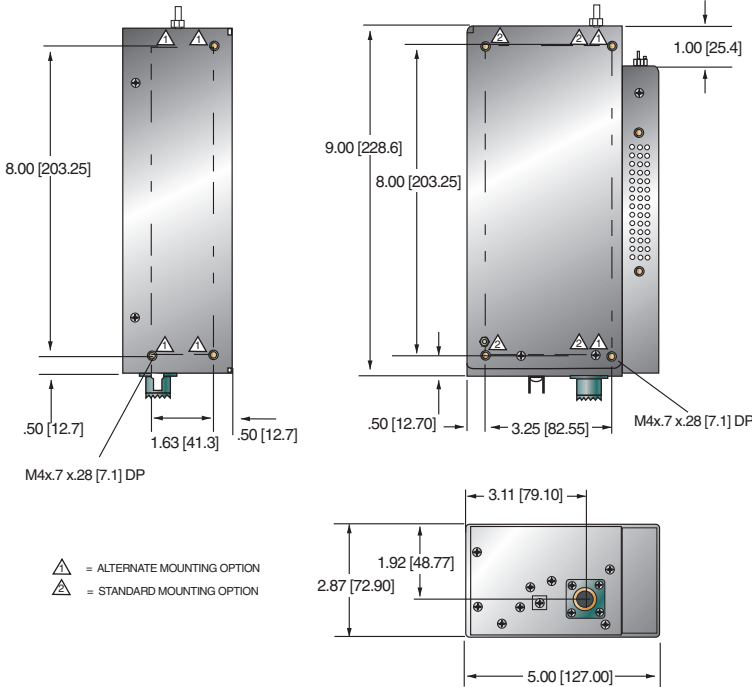

65KV WITH SIC OPTION

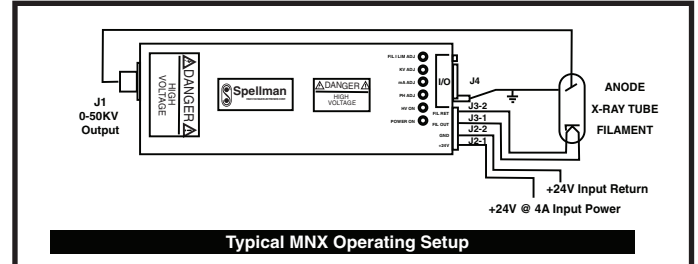
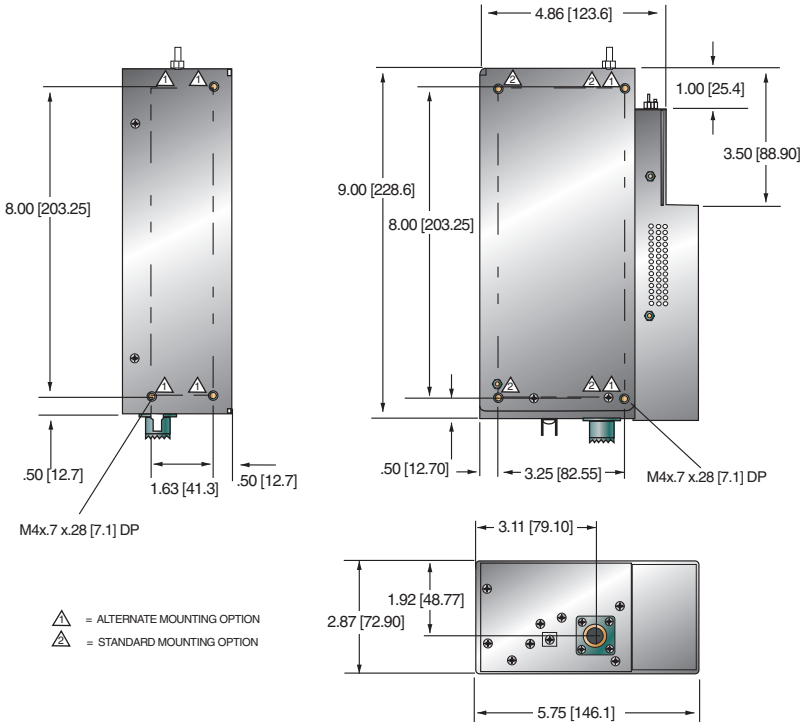

Typical MNX Operating Setup

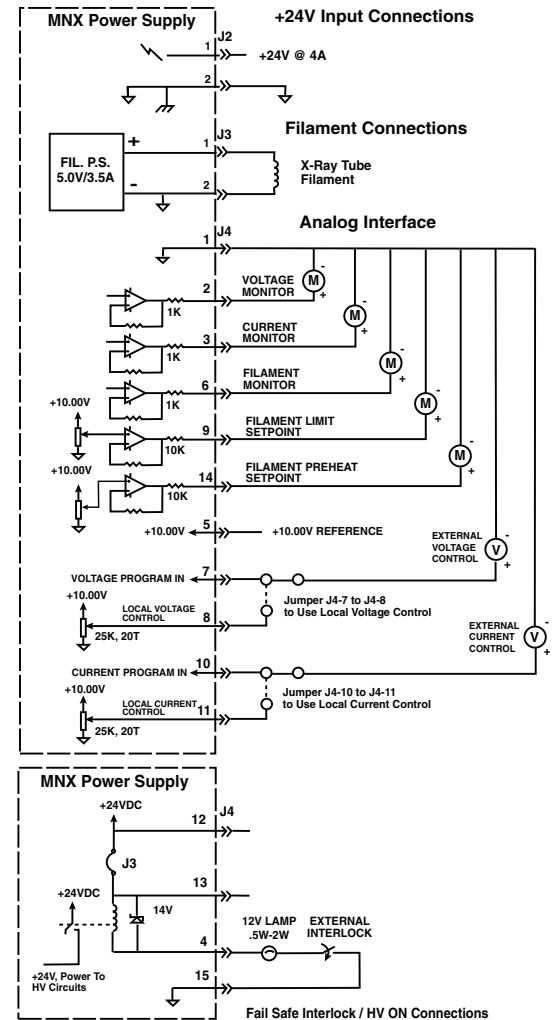

Alternate Interlock Configurations

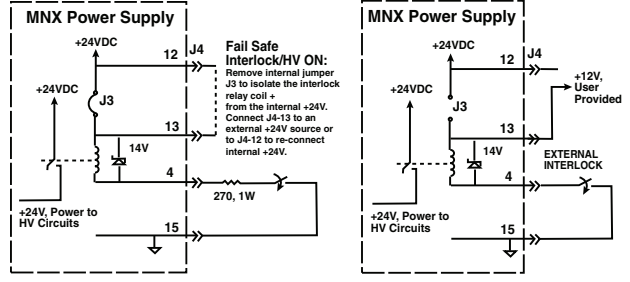

Alternate Interlock Configuration: Fail Safe Lamp Replaced With a 270 Ohm Resistor
 Alternate Interlock Configuration: Customer Provided +12V For HV ON Relay, Relay Return Grounded



IMPORTANT SAFETY PRECAUTIONS

SAFETY

THIS POWER SUPPLY GENERATES VOLTAGES THAT ARE DANGEROUS AND MAY BE FATAL.
OBSERVE EXTREME CAUTION WHEN WORKING WITH THIS EQUIPMENT.

High voltage power supplies must always be grounded.

Do not touch connections unless the equipment is off and the Capacitance of both the load and power supply is discharged.

Allow five minutes for discharge of internal capacitance of the power supply.

Do not ground yourself or work under wet or damp conditions.

SERVICING SAFETY

Maintenance may require removing the instrument cover with the power on.

Servicing should be done by qualified personnel aware of the electrical hazards.

WARNING note in the text call attention to hazards in operation of these units that could lead to possible injury or death.

CAUTION notes in the text indicate procedures to be followed to avoid possible damage to equipment.

Copyright © 2000, Spellman High Voltage Electronics Corporation. All Rights Reserved.
This information contained in this publication is derived in part from proprietary and patent data. This information has been prepared for the express purpose of assisting operating and maintenance personnel in the efficient use of the model described herein, and publication of this information does not convey any right to reproduce it or to use it for any purpose other than in connection with installation, operation, and maintenance of the equipment described.

WICHTIGE SICHERHEITSHINWEISE

SICHERHEIT

DIESES HOCHSPANNUNGSNETZTEIL ERZEUGT LEBENSGEFÄHRLICHE HOCHSPANNUNG.
SEIN SIE SEHR VORSICHTIG BEI DER ARBEIT MIT DIESEM GERÄT.

Das Hochspannungsnetzteil muß immer geerdet sein.

Berühren Sie die Stecker des Netzteiles nur, wenn das Gerät ausgeschaltet ist und die elektrischen Kapazitäten des Netzteiles und der angeschlossenen Last entladen sind.

Die internen Kapazitäten des Hochspannungsnetzteiles benötigen ca. 5 Minuten, um sich zu entladen.

Erden Sie sich nicht, und arbeiten Sie nicht in feuchter oder nasser Umgebung.

SERVICESICHERHEIT

Notwendige Reparaturen können es erforderlich machen, den Gehäusedeckel während des Betriebes zu entfernen.

Reparaturen dürfen nur von qualifiziertem, eingewiesenem Personal ausgeführt werden.

“WARNING” im folgenden Text weist auf gefährliche Operationen hin, die zu Verletzungen oder zum Tod führen können.

“CAUTION” im folgenden Text weist auf Prozeduren hin, die genauestens befolgt werden müssen, um eventuelle Beschädigungen des Gerätes zu vermeiden.

PRECAUTIONS IMPORTANTES POUR VOTRE SECURITE

CONSIGNES DE SÉCURITÉ

CETTE ALIMENTATION GÉNÈRE DES TENSIONS QUI SONT DANGEUREUSES ET PEUVENT ÊTRE FATALES.
SOYEZ EXTRÊMEMENT VIGILANTS LORSQUE VOUS UTILISEZ CET ÉQUIPEMENT.

Les alimentations haute tension doivent toujours être mises à la masse.

Ne touchez pas les connectiques sans que l'équipement soit éteint et que la capacité à la fois de la charge et de l'alimentation soient déchargées.

Prévoyez 5 minutes pour la décharge de la capacité interne de l'alimentation.

Ne vous mettez pas à la masse, ou ne travaillez pas sous conditions mouillées ou humides.

CONSIGNES DE SÉCURITÉ EN CAS DE REPARATION

La maintenance peut nécessiter l'enlèvement du couvercle lorsque l'alimentation est encore allumée.

Les réparations doivent être effectuées par une personne qualifiée et connaissant les risques électriques.

Dans le manuel, les notes marquées « **WARNING** » attire l'attention sur les risques lors de la manipulation de ces équipements, qui peuvent entraîner de possibles blessures voire la mort.

Dans le manuel, les notes marquées « **CAUTION** » indiquent les procédures qui doivent être suivies afin d'éviter d'éventuels dommages sur l'équipement.

IMPORTANTI PRECAUZIONI DI SICUREZZA

SICUREZZA

QUESTO ALIMENTATORE GENERA TENSIONI CHE SONO PERICOLOSE E POTREBBERO ESSERE MORTALI.
PONI ESTREMA CAUTELA QUANDO OPERI CON QUESTO APPARECCHIO.

- Gli alimentatori ad alta tensione devono sempre essere collegati ad un impianto di terra.
- Non toccare le connessioni a meno che l'apparecchio sia stato spento e la capacità interna del carico e dell'alimentatore stesso siano scariche.
- Attendere cinque minuti per permettere la scarica della capacità interna dell'alimentatore ad alta tensione.
- Non mettere a terra il proprio corpo oppure operare in ambienti bagnati o saturi d'umidità.

SICUREZZA NELLA MANUTENZIONE.

- Manutenzione potrebbe essere richiesta, rimuovendo la copertura con apparecchio acceso.
- La manutenzione deve essere svolta da personale qualificato, coscio dei rischi elettrici.
- Attenzione alle **AVVERTENZE** contenute nel manuale, che richiamano all'attenzione ai rischi quando si opera con tali unità e che potrebbero causare possibili ferite o morte.
- Le note di **CAUTELA** contenute nel manuale, indicano le procedure da seguire per evitare possibili danni all'apparecchio.

Table of Contents

PAGE

1. INTRODUCTION	
1.1 Description of the MNX Series.....	1
1.2 MNX Specifications.....	1
1.3 Standard Features.....	2
1.3.1 Remote Operating Features.....	2
1.4 Options.....	2
1.5 Interpreting the Model Number	2
2. INSPECTION & INSTALLATION	
2.1 Initial Inspection	3
2.2 Mechanical Installation.....	3
3. OPERATING INSTRUCTIONS	
3.1 Operation.....	7
3.2 Standard Features.....	8
4. PRINCIPLES OF OPERATION	
4.1 Chassis	13
4.2 Inverter.....	13
4.3 High Voltage Transformer	14
4.4 High Voltage Assembly.....	14
4.5 Control PWB.....	14
4.6 Filament Supply	14
4.7 Options.....	14
5. OPTIONS	
5.1 XCC Option	15
5.2 SIC Option	15
5.3 5VPM.....	15
5.4 Custom Designed Models.....	15
6. MAINTENANCE	
6.1 Periodic Servicing.....	16
6.2 Performance Test	16
6.3 High Voltage Dividers	16
7. REPLACEMENT PARTS	
7.1 Replacement Parts.....	17
7.2 Correspondence and Ordering Spare Parts	17
8. FACTORY SERVICE	
8.1 Warranty Repairs	18
8.2 Factory Service Procedures.....	18
8.3 Ordering Options and Modifications	18

8.4	Shipping Instructions	18
-----	-----------------------------	----

APPENDIX

- A. Specification Controls (Custom Models Only)
- B. Instruction Manual, SIC Option (SIC Models Only)

LIST OF FIGURES

Figure 2.1	Dimensions Standard MNX	4
Figure 2.2	Dimensions MNX with XCC Option.....	5
Figure 2.3	Dimensions MNX with SIC Option.....	6
Figure 3.1	Typical Operating Setup MNX.....	9
Figure 3.2	DC Input & Filament Connections	10
Figure 3.3	Monitors & Voltage/Current Control Connections.....	11
Figure 3.4	Recommended Interlock / HV on Connections	12

LIST OF TABLES

Table 1.1	Options.....	2
-----------	--------------	---

Chapter 1

INTRODUCTION

1.1 Description Of The MNX Series

The MNX series of high voltage power supplies represent an advanced approach to X-ray generator power requirements. These power supplies provide all the power, control, and support functions required for practically all X-ray applications. The MNX series provide high voltage, high current outputs with very low ripple. Extremely stable voltage and current outputs result in significant performance improvements over previously available technology. Low output ripple provides higher intensity levels, with no increase in tube loading.

All these advancements are possible only by Spellman's long history in X-ray power systems. This series of power supplies utilize extremely advanced resonant conversion techniques, along with sophisticated digital technology.

The MNX series is specifically designed for X-ray tube application where the high voltage is a positive polarity, and the filament circuits are referenced to the cathode ground potential, (grounded filament).

The X-ray tube voltage and tube emission current are all continuously adjustable.

The power supplies operate from +24Vdc and are convection cooled for 0 to 50W models. Custom designed units for single use or OEM applications are available.

1.2 MNX Specifications

- **Output Control:**
Voltage and current are continuously adjustable over the entire range from zero to maximum rating via a twenty-turn potentiometer.
- **Input Voltage:** 24Vdc \pm 10%
- **Voltage Regulation:**

Load regulation: 0.01% of full voltage for a no load to full load charge.

Line regulation: 0.01% of full voltage over specified input voltage range.

- **Current Regulation:**
Load regulation: 0.01% of full current from 0 to rated voltage.

Line regulation: \pm 0.01% of full current over specified voltage range.
- **Ripple:** 0.1% p-p of maximum output voltage.
- **Filament:** 3.5A, 5V
- **Stability:** 0.05% per 8 hours after ½ hour warm up.
- **Temperature Coefficient:** 0.01% per °C. Higher stability available on special order.
- **Ambient Temperature:**
0°C to 50°C operating.
-20°C to 85°C storage.
- **Weight:** 6.5 lbs. (2.9kg).
- **Standard Unit Size:** 5.00"H x 2.87"W x 8.00"D.
(127.0mm x 72.9mm x 203.20mm).
- **XCC Option Size:** 5.00"H x 2.87"W x 9.00"D.
(127.0mm x 72.9mm x 228.65mm).
- **SIC Option Size:** 5.75"H x 2.87"W x 8.00"D.
(146.05mm x 127.0mm x 203.20mm).

1.3 Standard Features

The MNX series incorporates several standard features designed to optimize user satisfaction and safety.

KV AND MA/FILAMENT CURRENT RAMP CIRCUITS: This feature provides for a gradual rise for kV, mA and filament current. This feature is designed to limit voltage shock and filament shock to the X-ray tube. The kV ramp rate is approximately 4 seconds. The filament current is slowly increased until the desired mA level is achieved. This time is typically 4 seconds for full mA output. These ramp conditions are started at the initial INTERLOCK CLOSED control signal. Prior to closing the Interlock the filament operates at a user determined preheat current level. Preheat levels are selected for the desired X-ray tube to minimize mA overshoot.

INDICATOR LEADS: HIGH VOLTAGE ON and POWER ON indicators.

OUTPUT CABLE: Standard units are provided with a 1 meter shielded high voltage output cable. The cables are designed with a plug arrangement so that they can be easily removed from the mating receptacle located on the front of the chassis. For non-standard units, see Spec. Control drawing.

LOCAL AND REMOTE PROGRAMMING: Potentiometers accessible through the top cover are provided for controlling tube voltage, tube emission current, tube filament limit set point and tube filament preheat set point.

Tube voltage and tube emission current can also be controlled remotely via the Analog Interface connector (J4).

1.3.1 Remote Operating Features

REMOTE MONITOR: Allows remote monitoring of the tube voltage, tube emission current, tube filament current, tube filament limit set point and tube filament preheat set point via the Analog Interface connector (J4).

EXTERNAL INTERLOCK: Interlock connections are provided on the Analog Interface connector (J4) on the front of the chassis for connection to a safety switch. The unit will not operate unless the interlock circuit is closed. The recommended configuration is to close the interlock circuit through a 12V lamp rated for 0.5W to 0.8W and a safety switch. This configuration provides fail safe interlocking. During high voltage operation, opening the safety switch or failure of the 12V lamp will cause the High Voltage to shut OFF. This option should be used for safety interlock circuits.

If fail-safe interlocking of the X-ray On is not required the lamp can be replaced with a 270 Ohm, 1 W resistor. Provisions are provided for isolating the interlock relay coil from the internal +24V, allowing the user to connect the coil to an external +12V source. This eliminates the need for either the lamp or the 270-Ohm resistor allowing J4-4 to be grounded for HIGH VOLTAGE ON control. See Figure 3.4 for alternate Interlock Configurations.

1.4 Options

CODE DESCRIPTION	
• XCC	XRM Compatible HV Cable
• SIC	Standard Interface Controller (Ethernet, USB & RS232)
• 5VPM	0-5 Volt Programming and Monitor Scaling.

Table 1.1 MNX Options

The options available are listed in Table 1.1. See Section 5 for more information on these options along with operating and set-up instructions. With few exceptions, these options and modifications can be retrofitted to your power supply at the factory in a short time. For price and retrofit arrangements, contact Spellman's Sales Department.

1.5 Interpreting the Model Number:

The model number of the power supply describes its capabilities. After the series name is:

- (1) the maximum voltage (in kV)
- (2) the maximum output (in watts)
- (3) the option codes for all options that are included.

Custom units have an X number after the option codes.

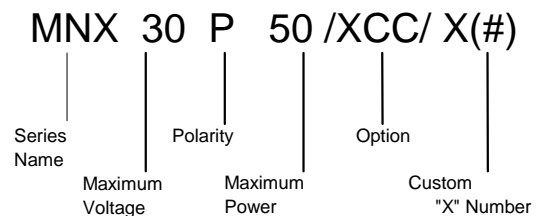

Chapter 2

Inspection and Installation

Initial inspection and preliminary checkout procedures are recommended. For safe operation, please follow the step-by-step procedures described in Chapter 3, Operating Instructions.

2.1 Initial Inspection

Inspect the package exterior for evidence of damage due to handling in transit. Notify the carrier and Spellman immediately if damage is evident. Do not destroy or remove any of the packing material used in a damaged shipment.

After unpacking, inspect the panel and chassis for visible damage.

Fill out and mail the Warranty Registration card accompanying the unit. Standard Spellman MNX high voltage power supplies and components are covered by warranty. Custom and special order models (with an X suffix in the model number) are also covered by warranty.

2.2 Mechanical Installation

Units in the MNX series have front panel holes for standard EIA rack mounting. The rack must allow rear access for cable connections. Units are fully enclosed and are suitable for bench or tabletop operation. Standard unit dimensions are shown in Figure 2.1.

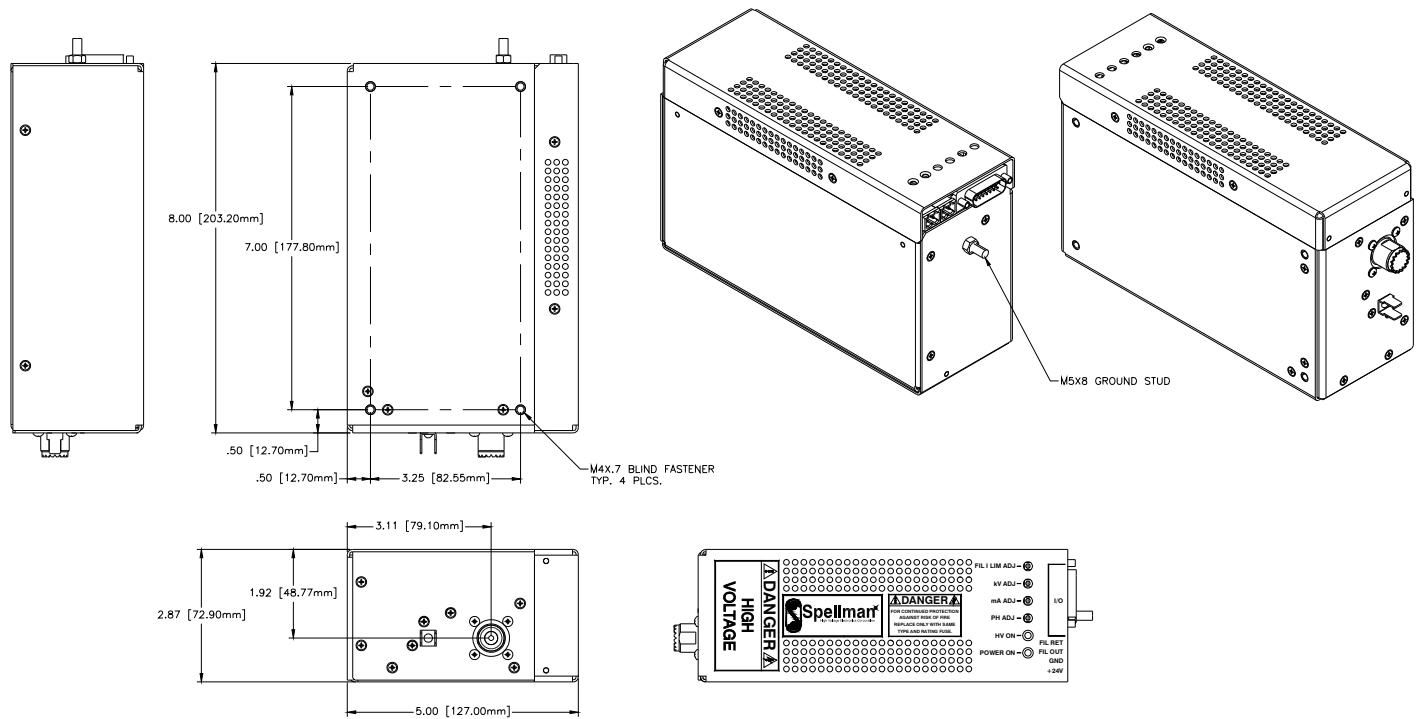

Figure 2.1 STANDARD MNX DIMENSIONS

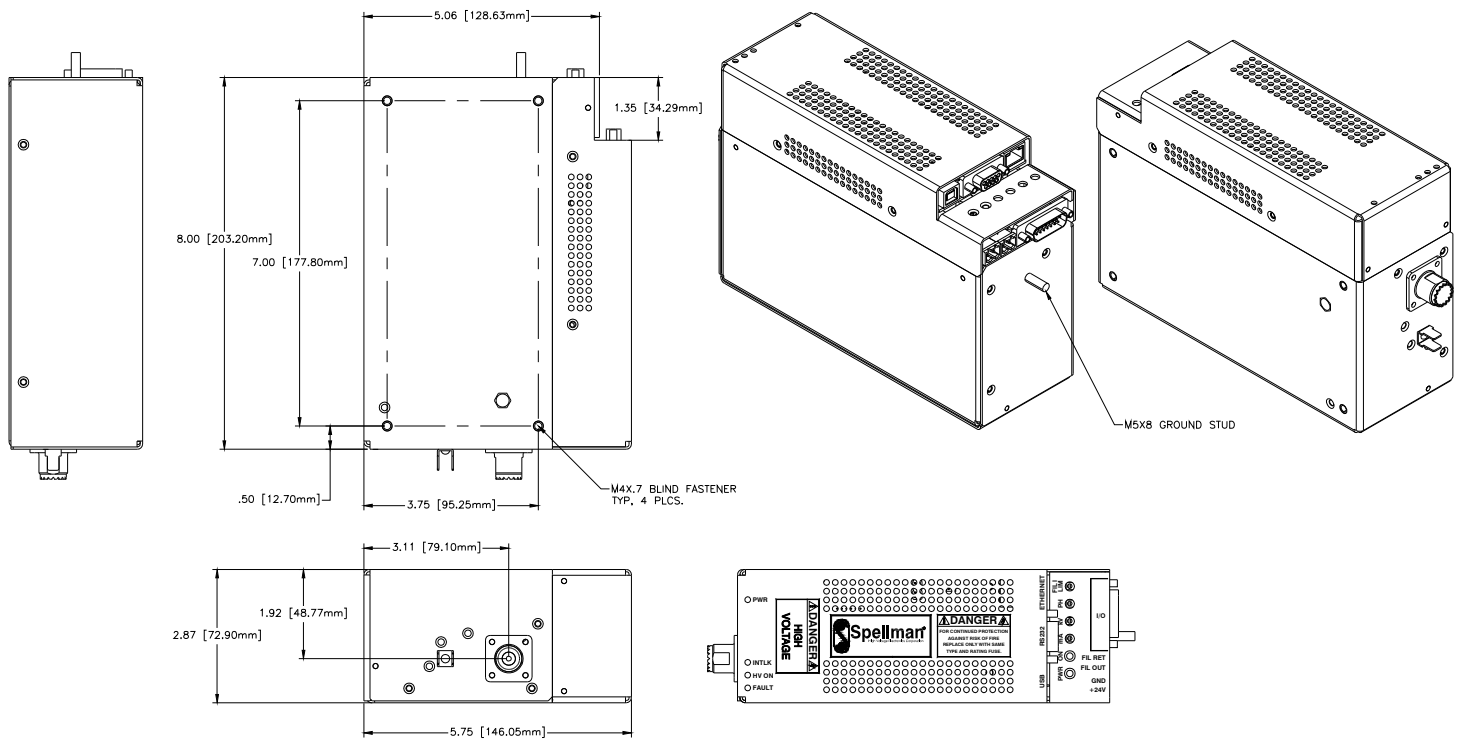

Figure 2.3 MNX DIMENSIONS WITH SIC OPTION

Chapter 3

Operating Instructions

3.1 Operation

WARNING

THIS EQUIPMENT GENERATES DANGEROUS VOLTAGES THAT MAY BE FATAL. PROPER GROUNDING OF ALL HIGH VOLTAGE EQUIPMENT IS ESSENTIAL.

WARNUNG

DIESES GERÄT ERZEUGT LEBENSGEFÄHRLICHE HOCHSPANNUNG. ALLE HOCHSPANNUNGSGERÄTE MÜSSEN ÜBER EINE GEEIGNETE ERDUNG VERFÜGEN.

IMPORTANT

Before connecting the power supply to the AC line, follow this step-by-step procedure.

Do not connect the power supply to the AC line until Step G is reached.

Failure to follow these procedures may void the warranty.

ACHTUNG

BEVOR SIE DAS HOCHSPANNUNGSNETZEIL AN DIE STROMVERSORGUNG ANSCHLIESSEN, MÜSSEN FOLGENDE PUNKTE GEPRÜFT WERDEN.

SCHLIESSEN SIE DAS HOCHSPANNUNGSNETZEIL NICHT AN DIE SPANNUNGSVERSORGUNG BEVOR PUNKT G ERREICHT IST. EVENTUELLE AUFTRETENDE BESCHÄDIGUNG DES GERÄTES DURCH NICHT BEFOLGEN DIESER ANWEISEN KANN ZUM VERLUST DES GARANTIEANSPRUCHES FÜHREN.

A) Check the input voltage rating on the nameplate of the supply and make certain that this is the rating of the available power source. Spellman MNX units operate on 24Vdc unless ordered with a different input voltage.

B) **PROPER GROUNDING TECHNIQUE:** The chassis of high voltage power supplies must be grounded, preferably to a water system ground using copper pipe or other earth ground using the connection terminal at the rear of the unit. See Figure 3.1, for a typical operating setup.

The return line from the load should be connected to the terminal on the rear of the power supply. Using a separate external ground at the load is not recommended.

C) Attach the output cable to the load.

D) Plug the high voltage output cable into the front of the supply and hand tighten the knurled collar.

E) **Options Note:** See section 5 for hook up and operating instructions for the options on your unit. Custom models may also require set up changes.

F) For initial turn-on, rotate the KILOVOLT control fully counter-clockwise to the zero voltage position.

G) The input power cable may now be connected and power applied. The POWER ON LED should light up. No high voltage will be generated at this time.

H) Close the INTERLOCK. The HIGH VOLTAGE ON LED should light up and the output will slow start to the preset level output voltage and/or output current.

NOTE: The MNX series is equipped with a slow start circuit that ramps the output up to its maximum setting in approximately 4 seconds after the INTERLOCK is closed.

I) To terminate the generation of output power, open the INTERLOCK. In the HIGH VOLTAGE OFF mode the power supply's fault and interface circuits are still active and the filament operates at the Preheat level.

J) To turn off the power supply, disconnect the power.

WARNING

AFTER TURNOFF, DO NOT HANDLE THE LOAD UNTIL THE CAPACITANCE HAS BEEN DISCHARGED!

LOAD CAPACITANCE MAY BE DISCHARGED BY SHORTING TO GROUND.

WARNUNG

Nach dem Ausschalten des Gerätes die Last erst berühren wenn diese vollständig entladen ist. Die elektrische Kapazität der Last kann durch einen Kurzschluß zur Erde entladen werden.

WARNING

THE VOLTAGE MONITOR ON THE POWER SUPPLY FRONT PANEL DOES NOT READ THE OUTPUT VOLTAGE WHEN THE POWER IS TURNED OFF, EVEN IF A CHARGE STILL EXISTS ON THE LOAD.

WARNUNG

Der Spannungsmonitor arbeitet nicht bei abgeschalteter Versorgungsspannung, auch nicht wenn die Last noch aufgeladen ist.

CAUTION

ALWAYS OPERATE THE UNIT WITH THE COVER ON. DO NOT ATTEMPT TO ACCESS OR REPAIR ANY INTERNAL CIRCUITS. DANGEROUS AND LETHAL VOLTAGES ARE GENERATED INSIDE THE MODULE.

CAUTION

Betreiben Sie das Hochspannungsnetzteil ausschließlich mit geschlossenem Gehäuse. Versuchen Sie nicht die internen Schaltkreise zu berühren oder zu reparieren, da lebensgefährliche Hochspannungen in Innern erzeugt werden.

3.2 Standard Features

A note on remote interface circuitry and remote signal grounding. Whenever possible, electrical isolation should be provided when interfacing with any high voltage power supply. For power control signals such as

EXTERNAL INTERLOCK, HIGH VOLTAGE OFF and HIGH VOLTAGE ON isolated relay contacts should be used. If possible, analog programming and monitoring signals should be isolated via analog isolation amplifiers. Spellman application engineers are available to assist in interface circuitry design. All interface cables should be properly shielded. All power supply signals should be referenced to the power supplies signal ground on J4-1.

LOCAL AND REMOTE PROGRAMMING: Allows the operator to select local or remote adjustment of the output voltage and current. Adjustments are made using the screwdriver adjustable potentiometers accessible through the top cover of the power supply or via an external voltage source provided by the operator. In local control jumpers are installed on connector J4 in the front of the chassis between J4-7 and J4-8 for voltage control and between J4-10 and J4-11 for current control.

For remote programming, the jumpers are removed and a positive voltage source, from 0 to 10 volts, is applied to the appropriate terminals. Programming signals should be referenced to J4-1 signal ground. By adjusting the voltage source from 0 volts (zero output) to 10 volts (full rated output) the desired output can be selected. 0 to 5 volts equals 0-100% of output on units with 5VPM option. See Figure 3.4 for wiring diagram and specifications.

An alternate method of controlling the output remotely is by using external resistance such as a potentiometer or a resistor network. For remote control the jumpers are removed and the desired resistor configuration is installed. See Figure 3.4 for wiring diagram.

REMOTE MONITOR: Test points are made available at J4 on the front of the chassis for monitoring the voltage, current and filament outputs and for reading the filament current limit and preheat set points. The test points are always positive regardless of the output polarity, where 0 to 10 volts equals 0-100% of output on standard units. 0 to 5 volts equals 0-100% of output on units with 5VPM option. Test points have an output impedance of 1K ohms. See Figure 3.3 for test point designation.

EXTERNAL INTERLOCK: Interlock connections are provided on J4-4 on the front of the chassis for connection to a safety switch. The unit will not operate unless the interlock circuit is closed. During high voltage operation, opening the interlock circuit will cause the unit to revert to the HIGH VOLTAGE OFF mode. See Figure 3.3 for the recommended interface circuit.

FILAMENT LIMIT: The maximum current that the filament power supply can operate is user adjustable from 1.0A to 3.5A. The Limit adjustment is made when the power supply is in the high voltage OFF mode (Interlock Open) via the screwdriver adjustable potentiometer labeled “FIL I LIM ADJ” that is accessible through the top cover.

A test point is provided on pin 9 of the Analog Interface connector (J4) for monitoring the Filament Limit set point. The test point scaling is 1VDC = 1ADC. See Figure 3.3 for the recommended interface circuit.

Due to the wide variety of X-ray tubes available, MNX power supplies are shipped with the Filament Limit set for minimum. The operator must set filament limit at the time of installation in accordance with the X-ray tube manufacturers recommendations.

FILAMENT PREHEAT: MNX filament power supplies operate at a user selectable preheat current level whenever the +24VDC input power is applied to the unit and the Interlock is Open (High Voltage OFF). The Preheat Level is adjustable from between .8A to 2.5A.

Selecting the correct preheat current level can greatly reduce or eliminate the overshoot that typically occurs on the output emission current when operating into a “cold filament”.

The Preheat adjustment is made when the power supply is in the high voltage OFF mode (Interlock Open) via the screwdriver adjustable potentiometer labeled “PH ADJ” that is accessible through the top cover.

A test point is provided on pin 14 of the Analog Interface connector (J4) for monitoring the Filament Preheat set point. The test point scaling is 1VDC = 1ADC. See Figure 3.3 for the recommended interface circuit.

Due to the wide variety of X-ray tubes available, MNX power supplies are shipped with the Filament Preheat set for minimum. The operator must set filament Preheat at the time of installation.

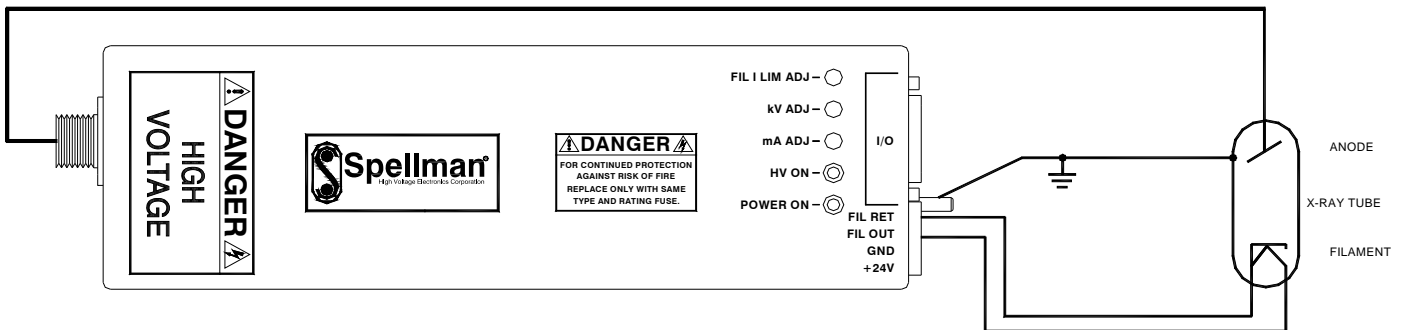

Figure 3.1 Typical Operating Setup MNX

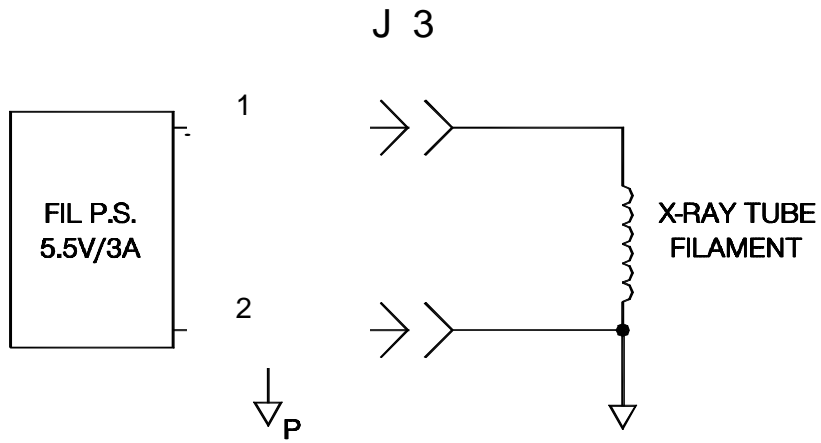
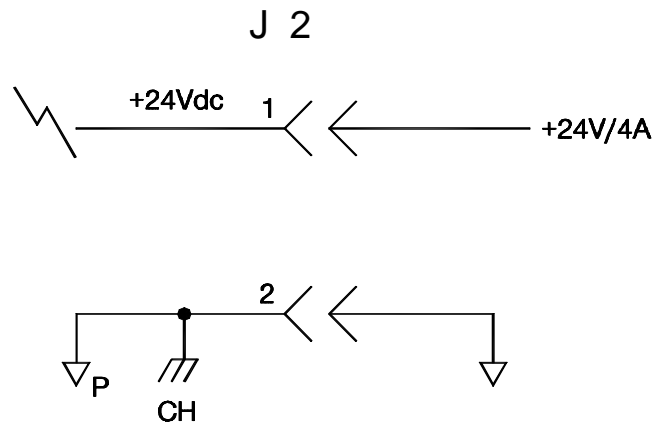

Table 3.2 DC Input & Filament Connections

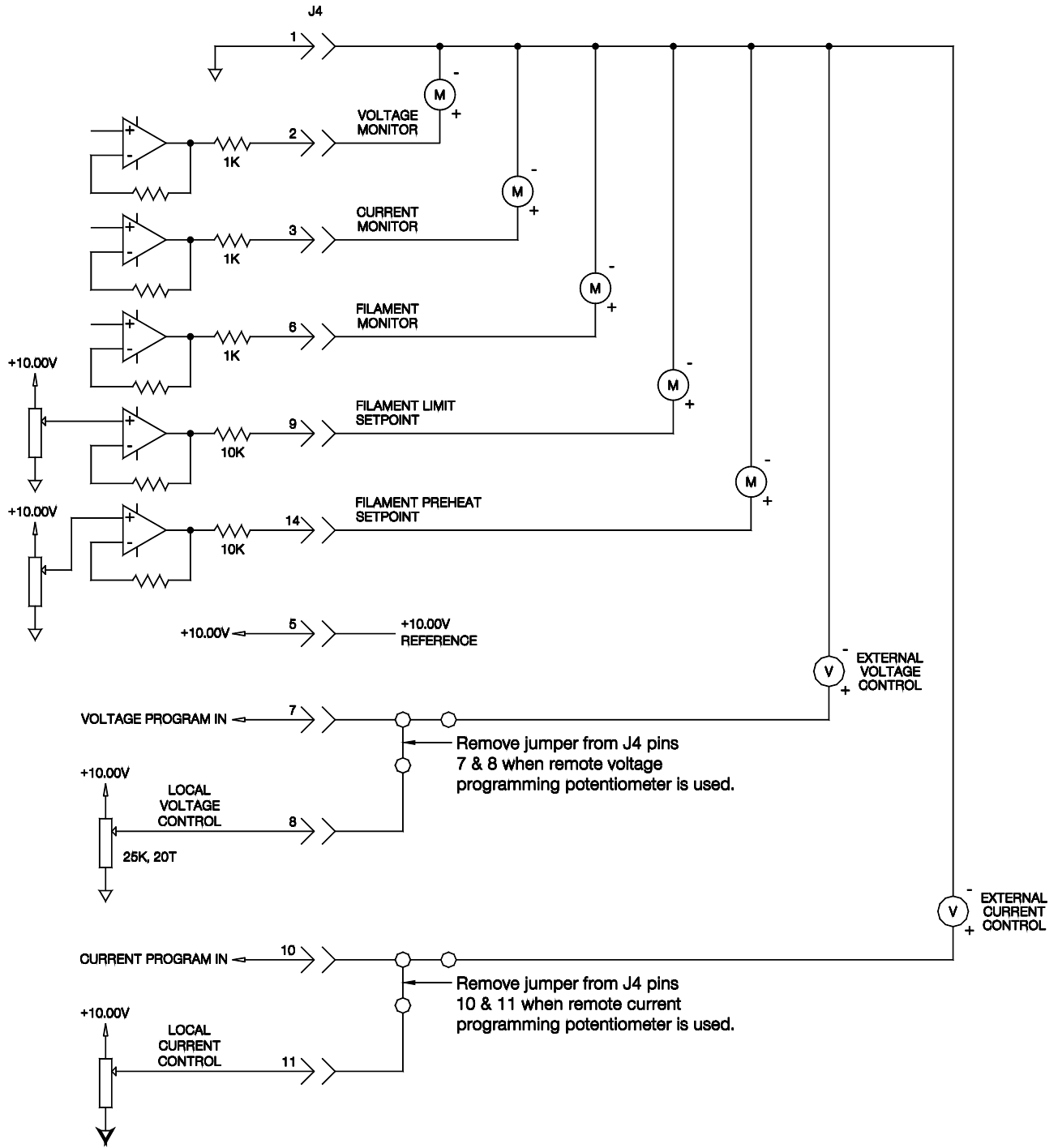
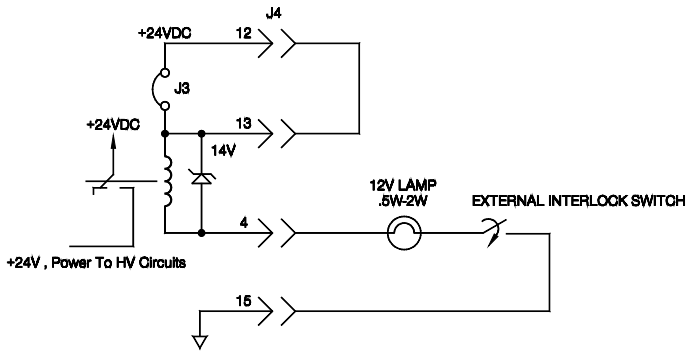
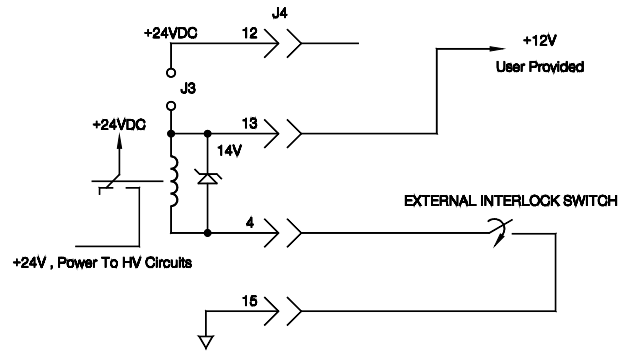

Figure 3.3 Monitors & Voltage/Current Control Connections



Recommended Interlock Configuration
With Fail Safe Lamp Installed



Alternate Interlock Configuration 2
Customer Provided +12V For HV ON Relay
Internal Jumper, J3, Removed
Relay Return Grounded

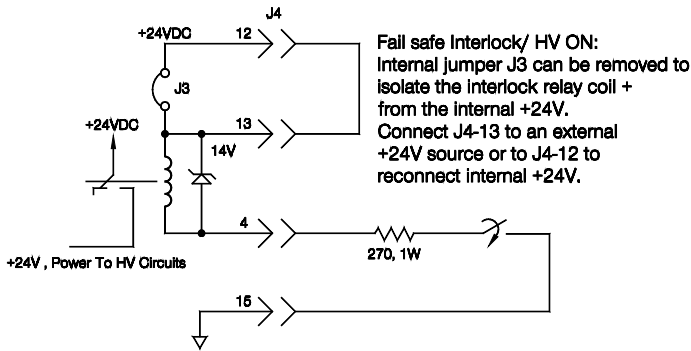

Alternate Interlock Configuration 1
Fail Safe Lamp Replaced With A Resistor

Fall safe Interlock/ HV ON:
Internal jumper J3 can be removed to
isolate the interlock relay coil +
from the internal +24V.
Connect J4-13 to an external
+24V source or to J4-12 to
reconnect internal +24V.

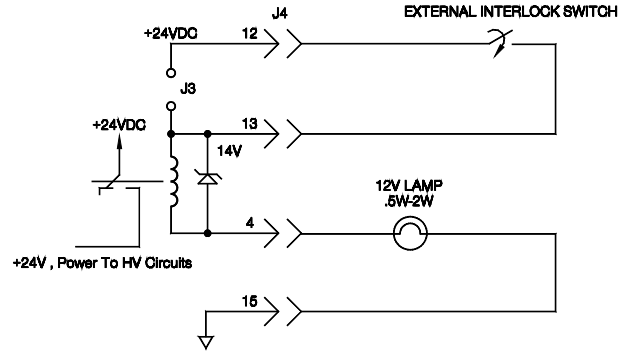

Alternate Interlock Configuration 3
Interlock Switch Installed In The High Side Of Relay Coil.
Relay Return Is Thru Lamp or 270 ohm Resistor.
This Configuration Is Required When SIC Option Is Installed.

Figure 3.4 Recommended Interlock/HV On Configurations

Chapter 4

Principles of Operation

The MNX series of high voltage power supplies utilizes sophisticated power conversion technology.

A variety of analog, digital and power conversion techniques are used throughout. The intention of the Principles of Operation is to introduce the basic function blocks that comprise the MNX power supply. For details on a specific circuit, consult Spellman's Engineering Department.

The MNX power supply is basically a DC-to-DC converter. Within the power supply, conversions of DC to high frequency AC, then to high voltage DC takes place. By reviewing further the sub-assemblies, a basic understanding of the process can be gained.

WARNING

To reduce the risk of fire, replace fuse with same type and rating.

WARNING

Um die Brandgefahr zu verringern, muss die Sicherung durch eine neue gleichen Typs ersetzt werden.

4.1 Chassis

The MNX is a compact, high efficiency, high voltage power supply. The power supply can supply up to 50 watts of DC power. (Output power capability may be higher or lower depending upon model ordered). Output voltages of up to 50kV can be generated.

WARNING

The energy levels used and generated by the power supply can be lethal! Do not attempt to operate the power supply unless the user has a sufficient knowledge of the dangers and hazards of working with high voltage. Do not attempt to approach or touch any internal or external circuits or components that are connected or have been connected to the power supply. Be certain to discharge any stored energy that may be present before and after the power supply is used. Consult IEEE recommended practices for safety in high voltage testing #510-1983.

WARNUNG

Die verwendete und erzeugte Energie des Hochspannungsnetztes kann tödlich sein! Betreiben Sie das Hochspannungsnetzteil nur wenn Sie ausreichendes Kenntnis über mögliche Gefahren beim Umgang mit der Hochspannung haben. Versuchen Sie nicht interne Schaltkreise oder elektrische Bauelemente, die an das Hochspannungsnetzteil angeschlossen sind, zu berühren. Vergewissern Sie sich, daß alle Restladungen, die vor oder nach dem Betrieb des Hochspannungsnetztes vorhanden sind, entladen werden. Weitere Informationen finden Sie der IEEE-Vorschrift Nr. 510-1983.

4.2 Inverter

The inverter is a series resonant, parallel loaded topology. A PWM scheme is used for regulating the power generated from the inverter. Q1 is a high speed MOSFET. This device provides high frequency switching to control the resonant current flow. The typical resonant operating period is approximately 15µ seconds.

4.3 High Voltage Transformer

The output of the High Frequency Resonant Inverter is connected to the primary of the High Voltage Transformer. The High Voltage Transformer is a step-up type. Typically secondary voltages are in the range of 5kV depending upon output voltage ratings.

4.4 High Voltage Assembly

The High Voltage Assembly will vary depending upon the model ordered. The circuitry typically consists of series arrangements of a half wave voltage multiplier. The higher voltage ranges utilize various series arrangements of a voltage doubler.

Output filtering is typically provided by an R-C type filter. A high bandwidth resistive/capacitive divider provides voltage feedback for regulation and monitoring. Current feedback for regulation and monitoring is provided by a sense resistor connected at the low voltage end of the High Voltage Rectifier/Multiplier Circuit.

4.5 Control PWB

The majority of control circuits for power supply controls are located on the CONTROL/POWER PWB.

+15VDC, -15VDC, and +10VDC are generated on the CONTROL/POWER PWB. High Voltage On/Off control is accomplished by K1, and its associated circuitry. Interlock control is provided by K1.

Voltage feedback from a high voltage divider, located on the High Voltage Assembly, is sent to U2. Gain adjustment is provided by R16. The KV feedback signal is sent to J4 for remote monitoring.

Program voltages are typically ramped up to set level by the slow start circuits of U4.

Current feedback from the high voltage rectifier is sent to sense resistors located on the High Voltage Assembly. Feedback is then sent to U1.

The resonant control circuitry consists of a voltage to pulse width converter. U6 generates all pulse width control signals.

4.6 Filament Supply

The filament inverter provides the power for the X-ray tube filament. The filament inverter is a high frequency inverter. The inverter provides regulated current to the primary of the filament transformer. The filament isolation transformer secondary is then connected to the output connector.

4.7 Options

Due to the many variations of models and options provided in the MNX series, details of actual circuits used may differ slightly from above descriptions. Consult Spellman's Engineering Department for questions regarding the principles of operations for the MNX series.

Chapter 5

OPTIONS

The options available for this power supply are described in this section. Interface diagrams are shown where required. Options are specified by including the option code in the model number as described in Section 1.5.

5.1 XRM Compatible Cable XCC

The XCC option allows the MNX power supply to except the same high voltage output cable that is used on the XRM series power supply.

5.2 Standard Interface Controller SIC

The SIC option adds a digital interface that allows the MNX power supply to be operated via an ether-net, USB or RS232 connection. The following features are available through the SIC interface:

- kV Programming
- kV Monitor
- mA Programming
- mA Monitor
- Filament Limit Set Point
- Filament Preheat Set Point
- Filament Current Monitor
- Filament Voltage Monitor
- Interlock Status
- High Voltage ON/OFF
- High Voltage ON Timer
- Unit Temperature

5.3 5 Volt Programming and Monitor 5VPM

5VPM changes the voltage and current programming inputs and monitors to 0-5V = 0-full rated output.

5.4 Custom Designed Models

X(#)

Units built to customer specifications are assigned an X number by the factory. If this unit is an X model, a specification control sheet is added at the end of this instruction manual.

Spellman welcomes the opportunity to tailor units to fit your requirements or to develop new products for your applications. Contact Spellman Sales Department with your needs.

Chapter 6

MAINTENANCE

This section describes periodic servicing and performance testing procedures.

WARNING

THIS POWER SUPPLY GENERATES VOLTAGES THAT ARE DANGEROUS AND MAY BE FATAL.

OBSERVE EXTREME CAUTION WHEN WORKING WITH HIGH VOLTAGE.

WARNUNG

DIESES HOCHSPANNUNGSNETZTEIL ERZEUGT LEBENSGEFÄHRLICHE HOCHSPANNUNG!

SEIEN SIE SEHR VORSICHTIG BEIM ARBEITEN MIT HOCHSPANNUNG!

6.1 Periodic Servicing

No periodic servicing is required on this module.

6.2 Performance Test

WARNING

HIGH VOLTAGE IS DANGEROUS. ONLY QUALIFIED PERSONNEL SHOULD PERFORM THESE TESTS.

WARNING

HOCHSPANNUNG IST GEFÄHRLICH!

NUR QUALIFIZIERTES PERSONAL DARF DIESE PRÜFUNGEN DURCHFÜHREN.

High voltage test procedures are described in Bulletin STP-783, Standard Test Procedures for High Voltage Power Supplies. Copies can be obtained from the Spellman Customer Service Department. Test equipment, including an oscilloscope, a high impedance voltmeter, and a high voltage divider such as the Spellman HVD-100 or HVD-200, is needed for performance tests. All test components must be rated for operating voltage.

6.3 High Voltage Dividers

High voltage dividers for precise measurements of output voltage with an accuracy up to 0.1% are available from Spellman. The HVD-100 is used for voltages up to 100KV. The HVD-200 measures up to 200KV. The Spellman divider is designed for use with differential voltmeters or high impedance digital voltmeters. The high input impedance is ideal for measuring high voltage low current sources, which would be overloaded by traditional lower impedance dividers.

Chapter 7

REPLACEMENT PARTS

7.1 Replacement Parts

Contact the Spellman Customer Service Department for parts lists for specific models.

Spellman provides parts and subassemblies for its high voltage power supplies but recommends that only qualified personnel perform the repair. High voltage is dangerous; even minor mistakes in repairs can have serious consequences.

When requesting parts please give the model number and serial number of the power supply

7.2 Correspondence And Ordering Spare Parts

Each Spellman power supply has an identification label on the rear of the chassis that bears its model and serial number.

When requesting engineering or applications information, please state the model and serial number of the power supply. If specific components or circuit sections are involved in the inquiry, it is helpful to indicate the component symbol number(s) shown on the applicable schematic diagram.

When ordering spare parts, please specify the part's description, the part's reference designation or part number, and the model and serial number of the unit.

Chapter 8

FACTORY SERVICE

8.1 Warranty Repairs

During the Warranty period, Spellman will repair all units free of charge. The Warranty is void if the unit is worked on by other than Spellman personnel. See the Warranty in the rear of this manual for more information. Follow the return procedures described in Section 8.2. The customer shall pay for shipping to and from Spellman.

8.2 Factory Service Procedures

Spellman has a well-equipped factory repair department. If a unit is returned to the factory for calibration or repair, a detailed description of the specific problem should be attached.

For all units returned for repair, please obtain an authorization to ship from the Customer Service Department, either by phone or mail prior to shipping. When you call, please state the model and serial numbers, which are on the plate on the rear of the power supply, and the purchase order number for the repair. A Return Material Authorization Code Number (RMA Number) is needed for all returns. This RMA Number should be marked clearly on the outside of the shipping container. Packages received without an RMA Number will be returned to the customer. The Customer shall pay for shipping to and from Spellman.

A preliminary estimate for repairs will be given by phone by Customer Service. A purchase order for this amount is requested upon issuance of the RMA Number. A more detailed estimate will be made when the power supply is received at the Spellman Repair Center. In the event that repair work is extensive, Spellman will call to seek additional authorization from your company before completing the repairs.

8.3 Ordering Options And Modifications

Many of the options listed in Chapter 5 can be retrofitted into Spellman power supplies by our factory. For prices and arrangements, contact our Sales Department.

8.4 Shipping Instructions

All power supplies returned to Spellman must be sent shipping prepaid. Pack the units carefully and securely in a suitable container, preferably in the original container, if available. The power supply should be surrounded by at least four inches of shock absorbing material. Please return all associated materials, i.e. high voltage output cables, interconnection cables, etc., so that we can examine and test the entire system.

All correspondence and phone calls should be directed to:

Spellman High Voltage Electronics Corp.
475 Wireless Boulevard
Hauppauge, New York 11788
TEL: (631) 630-3000 FAX: (631) 435-1620
E-Mail: sales@Spellmanhv.com
<http://www.spellmanhv.com>

SPELLMAN HIGH VOLTAGE ELECTRONICS

WARRANTY

Spellman High Voltage Electronics ("**Spellman**") warrants that all power supplies it manufactures will be free from defects in materials and factory workmanship, and agrees to repair or replace, without charge, any power supply that under normal use, operating conditions and maintenance reveals during the warranty period a defect in materials or factory workmanship. The warranty period is twelve (12) months from the date of shipment of the power supply. With respect to standard SL power supplies (not customized) the warranty period is thirty-six (36) months from the date of shipment of the power supply.

This warranty does not apply to any power supply that has been:

- Disassembled, altered, tampered, repaired or worked on by persons unauthorized by **Spellman**;
- subjected to misuse, negligent handling, or accident not caused by the power supply;
- installed, connected, adjusted, or used other than in accordance with the original intended application and/or instructions furnished by **Spellman**.

THE FOREGOING WARRANTY IS IN LIEU OF ALL OTHER WARRANTIES, EXPRESS OR IMPLIED, INCLUDING THOSE OF MERCHANTABILITY OR FITNESS FOR A PARTICULAR PURPOSE.

The buyer's sole remedy for a claimed breach of this warranty, and **Spellman's** sole liability is limited, at **Spellman's** discretion, to a refund of the purchase price or the repair or replacement of the power supply at **Spellman's** cost. The buyer will be responsible for shipping charges to and from **Spellman's** plant. The buyer will not be entitled to make claim for, or recover, any anticipatory profits, or incidental, special or consequential damages resulting from, or in any way relating to, an alleged breach of this warranty.

No modification, amendment, supplement, addition, or other variation of this warranty will be binding unless it is set forth in a written instrument signed by an authorized officer of **Spellman**.

Factory Service Procedures

For an authorization to ship contact **Spellman's** Customer Service Department. Please state the model and serial numbers, which are on the plate on the rear panel of the power supply and the reason for return. A Return Material Authorization Code Number (RMA number) is needed from **Spellman** for all returns. The RMA number should be marked clearly on the outside of the shipping container. Packages received without an RMA Number may delay return of the product. The buyer shall pay shipping costs to and from **Spellman**. Customer Service will provide the Standard Cost for out-of-warranty repairs. A purchase order for this amount is requested upon issuance of the RMA Number (in-warranty returns must also be accompanied by a "zero-value" purchase order). A more detailed estimate may be made when the power supply is received at **Spellman**. In the event that the cost of the actual repair exceeds the estimate, **Spellman** will contact the customer to authorize the repair.

Factory Service Warranty

Spellman will warrant for three (3) months or balance of product warranty, whichever is longer, the repaired assembly/part/unit. If the same problem shall occur within this warranty period **Spellman** shall undertake all the work to rectify the problem with no charge and/or cost to the buyer. Should the cause of the problem be proven to have a source different from the one that has caused the previous problem and/or negligence of the buyer, **Spellman** will be entitled to be paid for the repair.

Spellman Worldwide Service Centers

For a complete listing of **Spellman's** Global Service facilities please go to:
<http://www.spellmanhv.com/customerservice/service.asp>