

Instruction Manual

MONOBLOCK® SERIES XRB80N100

High Voltage X-Ray Generator

MODEL :
SERIAL# :
DATE :

**SPELLMAN
HIGH VOLTAGE ELECTRONICS
CORPORATION**

475 Wireless Blvd.
Hauppauge, New York, 11788

+1(631) 630-3000*FAX: +1(631) 435-1620*

E-mail: sales@spellmanhv.com

Website: www.spellmanhv.com



Spellman's new XRB80 Monoblock® X-Ray source is designed for OEM applications powering its internal X-Ray tube up to 80kV at 100 watts. Features like universal input, small package size and a standard analog and RS-232 digital interface simplify integrating the XRB80 into your X-Ray analysis system. Standard models are available either with fan shaped or cone shaped beam geometries. Proprietary emission control circuitry provides excellent regulation of X-Ray tube current, along with outstanding stability performance.

TYPICAL APPLICATIONS

Plating Measurement, Food Inspection, Fill Level Confirmation and Security Applications

SPECIFICATIONS

Input Voltage:

Power factor corrected input >0.98, 90-264Vac, 47-63 Hertz, 2 Amps, maximum

X-Ray Tube Voltage:

Nominal X-ray tube voltage is adjustable between 20kV to 80kV

X-Ray Tube Current:

150uA to 1.25mA over specified tube voltage range

X-Ray Tube Power:

100 watts, maximum

Voltage Regulation:

Line: $\leq 0.05\%$ of maximum output voltage over a $\pm 10\%$ change of nominal input line voltage
Load: $\leq 0.1\%$ of maximum rated voltage for 150uA to 1.25mA load change

Voltage Accuracy:

Voltage measured across the X-Ray tube is within $\pm 2\%$ of the programmed value

Voltage Risettime:

Standard: Ramp time shall be $\leq 500\text{mS}$ from 10% to 90% of maximum rated output voltage
Optional: 5 seconds. Specify at time of order

Voltage Overshoot:

$\leq 5\%$ of maximum voltage, to return within 2.5% of maximum voltage in less than 100mS

Voltage Ripple:

$\leq 1\%$ peak to peak of maximum voltage for frequencies ≤ 1 kHz

- **INTEGRATED HV SUPPLY, FILAMENT SUPPLY, X-RAY TUBE, BEAM PORT AND CONTROL ELECTRONICS**
- **COMPACT & LIGHTWEIGHT**
- **UNIVERSAL INPUT, POWER FACTOR CORRECTED WITH INTERNAL EMI FILTER**
- **CAN BE MOUNTED IN ANY PHYSICAL ORIENTATION**
- **ANALOG CONTROL INTERFACE AND STANDARD RS-232 DIGITAL INTERFACE**

www.spellmanhv.com/manuals/XRB80

Voltage Temperature Coefficient:

$\leq 100\text{ppm}/^\circ\text{C}$

Emission Current Parameters

Current Regulation:

Line: $\leq 0.05\%$ of rated output current over a $\pm 10\%$ change of nominal input line voltage
Load: $\leq 0.1\%$ of rated output current for a change from 50% to 100% of rated output voltage

Current Accuracy:

Current measured through the X-Ray tube is within $\pm 2\%$ of the programmed value

Current Risettime:

Standard: Ramp time shall be $\leq 500\text{mS}$ from 10% to 90% of maximum rated current
Optional: 5 seconds. Specify at time of order

Current Temperature Coefficient:

$\leq 100\text{ppm}/^\circ\text{C}$

Arc Intervention:

Standard: 3 arcs in 10 seconds with a 200mS quench = Shutdown
Optional: 1 arc = Shutdown. Specify at time of order

Filament Configuration:

High frequency AC filament drive; referenced to cathode potential of the X-Ray tube. Closed loop filamentary emission control circuit regulates filament current to provide desired X-Ray tube emission current.

X-Ray Tube:

Focal Spot:

Standard: 1.5mm (IEC 336) SHV part number 105739-043
Optional: 0.8mm (IEC 336) SHV part number 105739-045
0.5mm (IEC 336) SHV part number 105739-046
Specify at time of order

Beam Filter: Ultem: 3.30mm $\pm 0.15\text{mm}$
Oil: 8mm $\pm 0.1\text{mm}$
Glass: 1mm $\pm 0.25\text{mm}$

Fan Beam: Standard. The beam angular coverage will be 75 degrees with the beam plane perpendicular to the X-Ray tube axis and 13 degrees wide.

Cone Beam: Optional. 25 degree cone beam

Analog Interface:

Ground referenced 0 to 9Vdc for all programming and monitoring signals. Relay contacts and open collector signals for other signals. See analog interface connector pin out table.

Digital Interface:

Jumpers are needed to be configured and the digital interface cable installed to enable the RS232 interface.

Control Software:

A demo GUI will be provided for the RS-232 digital interface.

Interlock/Signals:

A hardware interlock functions in both analog and digital programming modes. The hardware X-Ray Enable signal only functions in analog programming mode.

Operating Temperature:

0°C to +40°C

Storage Temperature:

-40°C to +70°C

Humidity:

10% to 95% relative humidity, non-condensing

Cooling:

Natural convection augmented by customer provided 100CFM external cooling fan as required.

Input Line Connector:

3 pin, Phoenix Contact 1829167, SHV part number 105725-219. Mating connector Phoenix Contact #1805990, SHV part number 105808-475 provided with unit.

Analog Interface Connector:

15 pin D connector, male

Digital Interface Connector:

9 pin D connector, female

Grounding Point:

8-32 ground stud provided on chassis

Dimensions:

9.6" L X 7.6" W X 7.0" H
(243.8mm x 193.0mm x 177.8mm)

Weight:

≤32 pounds (14.5 kg)

Orientation:

Can be mounted in any orientation.

X-Ray Leakage:

Not to be greater than 0.5mR/hr at 5cm outside the external surface per FDA 21 CFR 1020.40 and OSHA 29 CFR 1020.96

Regulatory Approvals:

Compliant to 2004/108/EC, The EMC Directive and 2006/95/EC, The Low Voltage Directive, UL/CUL recognized file E148969

**AC LINE POWER CONNECTOR—
J1 THREE POSITION PHOENIX CONTACT**

PIN	SIGNAL
1	Earth Ground
2	Line
3	Neutral

Mating connector provided with unit

**RS-232 DIGITAL INTERFACE—
J3 9 PIN FEMALE D CONNECTOR**

PIN	SIGNAL	PARAMETERS
1	N/C	No Connection
2	TD	Transmit Data
3	RD	Receive Data
4	N/C	No Connection
5	SGND	Signal Ground
6	NC	No Connection
7	NC	No Connection
8	NC	No Connection
9	NC	No Connection

**XRB ANALOG INTERFACE—
J2 15 PIN MALE D CONNECTOR**

PIN	SIGNAL	PARAMETERS
1	Power Supply Fault Output	Open collector, 35 volts @ 10mA max. high = no fault
2	mA Program Input	0 to 9.00Vdc = 0 to 100% rated output, Zin = 10MΩ
3	kV Program Input	0 to 9.00Vdc = 0 to 100% rated output, Zin = 10MΩ
4	X-Ray On Lamp Relay Output	Common, dry contacts, 30Vdc @ 1 amp, max.
5	X-Ray On Lamp Relay Output	Normally open, X-Ray ON = closed
6	mA Monitor Output	0 to 9Vdc = 0 to 100% rated output, Zout = 10kΩ
7	X-Ray On Lamp Relay Output	Normally closed, X-Ray ON = open
8	kV Monitor Output	0 to 9.00Vdc = 0 to 100% rated output, Zout = 10kΩ
9	Signal Ground	Ground
10	Signal Ground	Ground
11	HV Interlock Return Input	Connect to Pin 12 to close HV interlock
12	HV Interlock Output	+15Vdc @ open, ≤5mA when connected to pin 11
13	X-Ray Enable Output	+15Vdc @ open, ≤5mA when connected to pin 15
14	X-Ray Status Output	Open collector, 35 volts @ 10mA max. high = X-Ray OFF
15	X-Ray Enable Return Input	Connect to pin 13 to enable X-Ray generation

LED INDICATORS

INDICATOR	SIGNAL NAME	CONDITION Illuminated When...
LED 1	OV	High kV occurs
LED 2	UV	Low kV occurs
LED 3	UC	Low mA occurs
LED 4	OC	High mA occurs
LED 5	ARC FLT	Arc fault occurs
LED 6	OT	Over temperature occurs
LED 7	X-RAY ON	X-Rays are enabled
LED 8	PWR	Power is ON

OPTIONS

- RT** 5 second Risetime for both voltage and current
- ARC** 1 arc = Shutdown
- CB** Cone Beam
- 0.8mm** 0.8mm focal spot, SHV part number 105739-045
- 0.5mm** 0.5mm focal spot, SHV part number 105739-046

How to Order:
Standard: PART NO.: XRB80N100
Risetime and Cone Beam Options: PART NO.: XRB80N100/RT/CB

DIMENSIONS: in.[mm]

FRONT VIEW

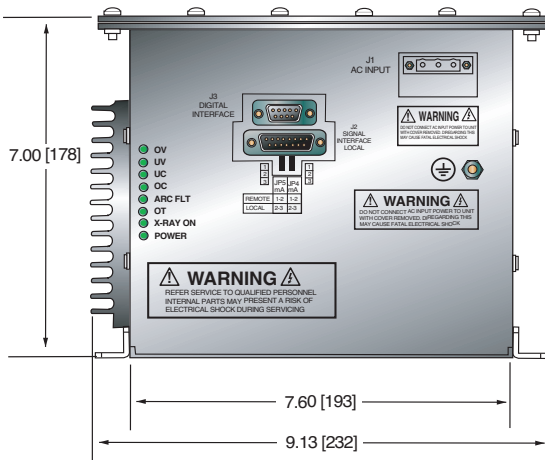

SIDE VIEW

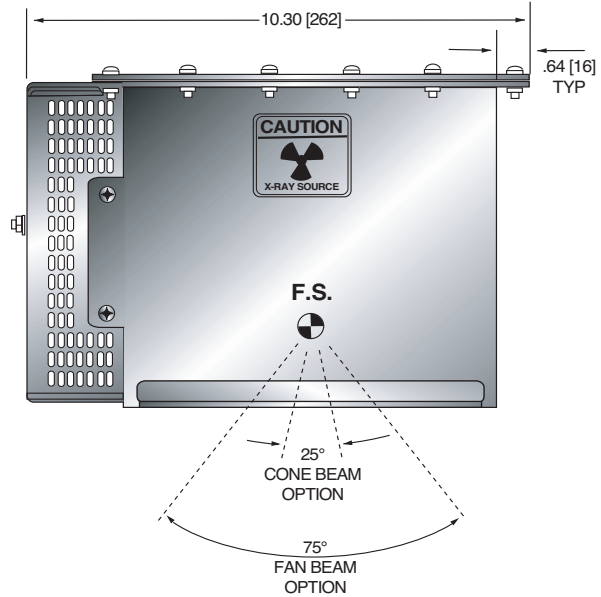

BACK VIEW

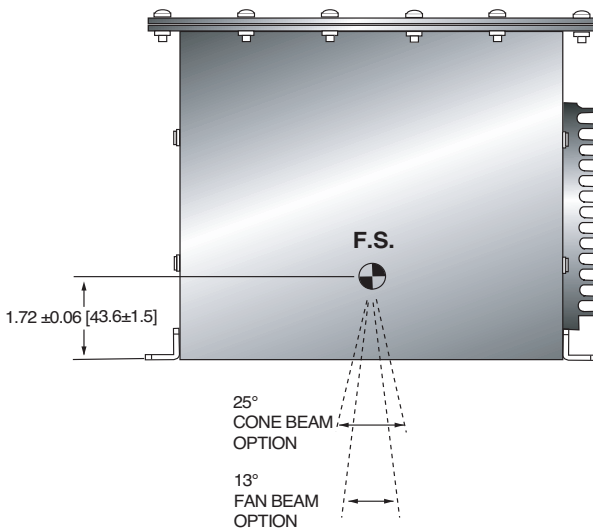

BOTTOM VIEW

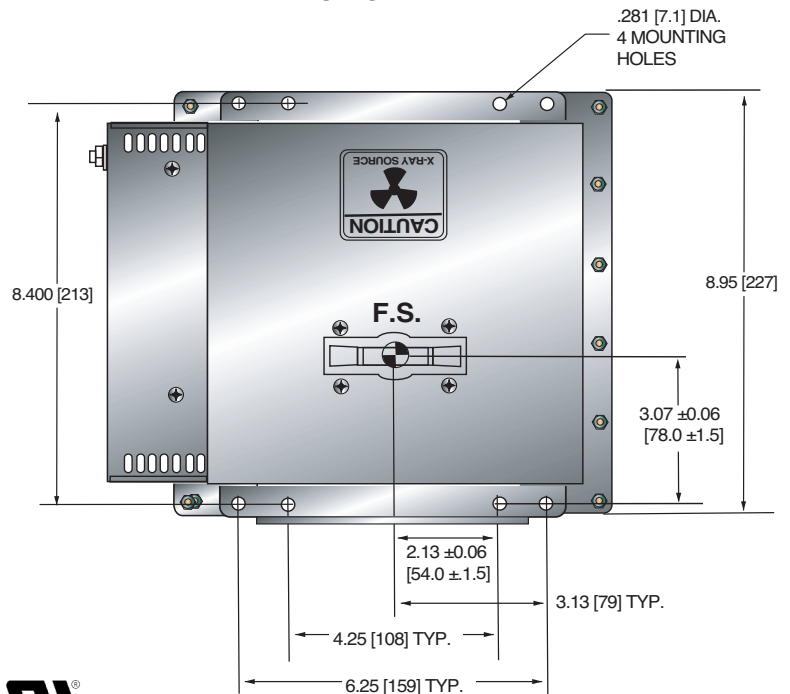

IMPORTANT SAFETY PRECAUTIONS

SAFETY

THIS POWER SUPPLY GENERATES VOLTAGES THAT ARE DANGEROUS AND MAY BE FATAL.
OBSERVE EXTREME CAUTION WHEN WORKING WITH THIS EQUIPMENT.

High voltage power supplies must always be grounded.

Do not touch connections unless the equipment is off and the Capacitance of both the load and power supply is discharged.

Allow five minutes for discharge of internal capacitance of the power supply.

Do not ground yourself or work under wet or damp conditions.



SERVICING SAFETY

Maintenance may require removing the instrument cover with the power on.

Servicing should be done by qualified personnel aware of the electrical hazards.

WARNING note in the text call attention to hazards in operation of these units that could lead to possible injury or death.

CAUTION notes in the text indicate procedures to be followed to avoid possible damage to equipment.

Copyright © 2000, Spellman High Voltage Electronics Corporation. All Rights Reserved.
This information contained in this publication is derived in part from proprietary and patent data. This information has been prepared for the express purpose of assisting operating and maintenance personnel in the efficient use of the model described herein, and publication of this information does not convey any right to reproduce it or to use it for any purpose other than in connection with installation, operation, and maintenance of the equipment described.

WICHTIGE SICHERHEITSHINWEISE

SICHERHEIT

DIESES HOCHSPANNUNGSNETZTEIL ERZEUGT LEBENSGEFÄHRLICHE HOCHSPANNUNG.
SEIN SIE SEHR VORSICHTIG BEI DER ARBEIT MIT DIESEM GERÄT.

Das Hochspannungsnetzteil muß immer geerdet sein.

Berühren Sie die Stecker des Netzteiles nur, wenn das Gerät ausgeschaltet ist und die elektrischen Kapazitäten des Netzteiles und der angeschlossenen Last entladen sind.

Die internen Kapazitäten des Hochspannungsnetzteiles benötigen ca. 5 Minuten, um sich zu entladen.

Erden Sie sich nicht, und arbeiten Sie nicht in feuchter oder nasser Umgebung.



SERVICESICHERHEIT

Notwendige Reparaturen können es erforderlich machen, den Gehäusedeckel während des Betriebes zu entfernen.

Reparaturen dürfen nur von qualifiziertem, eingewiesenem Personal ausgeführt werden.

“WARNING” im folgenden Text weist auf gefährliche Operationen hin, die zu Verletzungen oder zum Tod führen können.

“CAUTION” im folgenden Text weist auf Prozeduren hin, die genauestens befolgt werden müssen, um eventuelle Beschädigungen des Gerätes zu vermeiden.

PRECAUTIONS IMPORTANTES POUR VOTRE SECURITE

CONSIGNES DE SÉCURITÉ

CETTE ALIMENTATION GÉNÈRE DES TENSIONS QUI SONT DANGEUREUSES ET PEUVENT ÊTRE FATALES.
SOYEZ EXTRÊMEMENT VIGILANTS LORSQUE VOUS UTILISEZ CET ÉQUIPEMENT.

Les alimentations haute tension doivent toujours être mises à la masse.

Ne touchez pas les connectiques sans que l'équipement soit éteint et que la capacité à la fois de la charge et de l'alimentation soient déchargées.

Prévoyez 5 minutes pour la décharge de la capacité interne de l'alimentation.

Ne vous mettez pas à la masse, ou ne travaillez pas sous conditions mouillées ou humides.



CONSIGNES DE SÉCURITÉ EN CAS DE REPARATION

La maintenance peut nécessiter l'enlèvement du couvercle lorsque l'alimentation est encore allumée.

Les réparations doivent être effectuées par une personne qualifiée et connaissant les risques électriques.

Dans le manuel, les notes marquées « **WARNING** » attire l'attention sur les risques lors de la manipulation de ces équipements, qui peuvent entraîner de possibles blessures voire la mort.

Dans le manuel, les notes marquées « **CAUTION** » indiquent les procédures qui doivent être suivies afin d'éviter d'éventuels dommages sur l'équipement.

IMPORTANTI PRECAUZIONI DI SICUREZZA

SICUREZZA

QUESTO ALIMENTATORE GENERA TENSIONI CHE SONO PERICOLOSE E POTREBBERO ESSERE MORTALI.
PONI ESTREMA CAUTELA QUANDO OPERI CON QUESTO APPARECCHIO.

- Gli alimentatori ad alta tensione devono sempre essere collegati ad un impianto di terra.
- Non toccare le connessioni a meno che l'apparecchio sia stato spento e la capacità interna del carico e dell'alimentatore stesso siano scariche.
- Attendere cinque minuti per permettere la scarica della capacità interna dell'alimentatore ad alta tensione.
- Non mettere a terra il proprio corpo oppure operare in ambienti bagnati o saturi d'umidità.



SICUREZZA NELLA MANUTENZIONE.

- Manutenzione potrebbe essere richiesta, rimuovendo la copertura con apparecchio acceso.
- La manutenzione deve essere svolta da personale qualificato, coscio dei rischi elettrici.
- Attenzione alle **AVVERTENZE** contenute nel manuale, che richiamano all'attenzione ai rischi quando si opera con tali unità e che potrebbero causare possibili ferite o morte.
- Le note di **CAUTELA** contenute nel manuale, indicano le procedure da seguire per evitare possibili danni all'apparecchio.

Table of Contents

	PAGE
1. INTRODUCTION	
1.1 Description of MONOBLOCK® Series	2
1.2 MONOBLOCK® Series Specifications	2
1.3 Operating Features	3
1.4 Status and Fault Diagnostic Display	4
1.5 Interpreting the Model Number	5
2. INSPECTION	
2.1 Initial Inspection	6
2.2 Installation	6
3. OPERATING INSTRUCTIONS	
3.1 Operation	7
3.2 Signal and Power Connections	8
3.3 Local Mode (Analog Control)	8
3.4 Local Mode (Analog Monitors)	8
3.5 Local Mode (Analog Enable)	8
3.6 Remote Mode (Digital Control)	8
3.7 X-Ray Tube Seasoning Process	8
4. DIAGNOSTICS	
4.1 Chassis	11
5. FACTORY SERVICE	
5.1 Warranty Repairs	12
5.2 Factory Service Procedures	12
5.3 Ordering Options and Modifications	12
5.4 Shipping Instructions	12

LIST OF TABLES

Table 1	Diagnostic Descriptions	11
Table 2	Tube Seasoning Procedure	13

Chapter 1

INTRODUCTION

1.1 Description of the XRB80N100 MONOBLOCK® Series

The XRB80N100 MONOBLOCK® Series is a complete integrated system consisting of a high voltage power supply (HVPS), filament supply, X-ray tube and oil encapsulant which provides the required high voltage insulation in one compact enclosure. The combination of proprietary control system and protection circuitry enables the supplies to operate under arcing and extreme transient conditions without damage or interruptions. Additional advantages are the elimination of high voltage cables and extremely low leakage X-ray radiation.

Power factor corrected input regulator is utilized to improve overall reduction in harmonic emissions and EMI. The output provides a regulated +390VDC to downstream switching circuitry enabling optimal performance and efficiency.

The XRB80 MONOBLOCK® Series incorporates local and remote programming, monitoring, and fault indicators including safety interlock.

The X-ray source is a sealed unit containing a HVPS and an X-ray tube. The insulating oil provides electrical insulation for the high voltage sections of the power supply and the X-ray tube in a sealed tank. The oil also functions as a coolant to carry heat away from the tube. Convection cooling augmented by customer provided 100cfm external fan is required. A rubber bellows in the tank of the X-ray source compensates for the expansion of the oil as the oil temperature varies with operating conditions thereby eliminating the need for bulky overflow tank.

1.2 MONOBLOCK® Specifications

- **Input voltage:** 90-264V, 50-60Hz, 2A_{RMS} max.
- **HV Output Power:** 40kV - 80kV @ 0.15 - 1.25mA
- **Voltage Accuracy:** Voltage measured across the X-ray tube is within $\pm 2\%$ of the programmed value.
- **Output voltage Regulation:**
- **Line Regulation:** $\pm 0.05\%$ of maximum rated voltage for a $\pm 10\%$ change in nominal input line voltage.
- **Load Regulation:** $\leq 0.1\%$ of maximum rated voltage for a 0.15mA to 1.25mA load change.
- **Voltage rise time:**
Standard: Ramp time shall be $\leq 500\text{ms}$ from 10% to 90% of maximum rated output voltage
Optional: 5 seconds .Specify at time of order.
- **Current Accuracy:** Voltage measured through the X-ray tube is within $\pm 2\%$ of the programmed value.
- **Current Regulation:**
Line Regulation: $\pm 0.05\%$ of rated current for a $\pm 10\%$ change in nominal input line voltage.
Load Regulation: $\leq 0.1\%$ of rated current for a 50% to 100% output voltage change.
- **Current rise time:**
Standard: Ramp time shall be $\leq 500\text{ms}$ from 10% to 90% of maximum rated current
Optional: 5 seconds .Specify at time of order.
- **Temperature Coefficient:** $\leq 100\text{ppm} / ^\circ\text{C}$.
- **Temperature:**
Operating: 0°C to 40°C
Storage: -40°C to $+70^\circ\text{C}$

- **Analog Programming inputs:**
0-9 VDC corresponding to 0- 80.0kv output voltage
0-9VDC corresponding to 0-1.25ma output current.
- **Monitoring:**
0-9 VDC corresponding to 0- 80.0kv output voltage
0-9VDC corresponding to 0-1.25ma output current.
- **X-ray Beam Geometry:** Fan beam 75°x13°
Optional Cone beam: 25°
- **X-ray Beam Filtration:**
- 0.125 “+0.00” - 0.013” Lexan window
- 8mm ± 0.1mm Oil
- 1.0mm ±0.25mm glass (X-ray tube)
- **Focal spot size:** 1.5mm x 1.5mm (IEC336)
- **Target material, anode angle:** Tungsten, 35°

For detailed specifications please refer to Specification Control Drawing 128065-001

1.3 Operating Features

The MONOBLOCK® Series incorporates several standard features designed to optimize user satisfaction and safety.

- **INTERNAL FAULT PROTECTION:** The MONOBLOCK® Series continually monitors internal circuits critical to the proper operation of the power supply. In the event that one of these circuits does not function correctly, the fault detection circuit latches the appropriate fault on the front cover display and turns off the output.
- **LED FAULT/STATUS INDICATORS:**
Indicators are located on the cover of Inverter/Control Assembly and are provided to give the user complete indication of system operation and fault conditions.

POWER	OVERVOLTAGE (OV)
ARC FLT	UNDervOLTAGE (UV)
OVERTEMP (OT)	OVER CURRENT (OC)
UNDER CURRENT (UC)	X-RAY ON
- **WATCHDOG OPERATION:** The HVPS employs an internal watchdog timer to discontinue X-ray operation in instances where the host computer has lost communication and control of the HVPS system

for a period greater than ten second. This feature is enabled via RS-232 host command.

- **LOCAL PROGRAMMING:** Allows Local adjustment of the output voltage and current via analog voltage inputs on J2 on the front cover. To operate in Local mode, position jumpers for JP4 and JP5 in the 2-3 position as per table on the front cover.
- **LOCAL MONITORS:** provides Local analog monitors for the output voltage and current via analog voltage outputs on J2 on the front cover.
- **REMOTE PROGRAMMING:** Allows remote adjustment of the output voltage and current via RS-232 digital interface port at J3 on the front cover. To operate in Remote mode, position jumpers for JP4 and JP5 in the 1-2 position as per table on the front cover. All program values default to zero upon power up.
- **REMOTE MONITORS:** Provides remote monitors of the output voltage, output current and Filament current via RS-232 digital interface port at J3 on the front cover.
- **X-RAY ENABLE CONTROL:** Provides control of X-ray ON and X-ray OFF either via a dry contact connection from J2-15 to J2-13 when operating in Local Mode (analog control) or Remote Mode RS-232 communication when operating in remote mode. Upon power up the unit will default to Local Mode and will require re-assertion of J2-15 to enable unit. After an X-ray Enable command is received via RS-232 the unit will switch to Remote Mode.
- **EXTERNAL INTERLOCK:** The X-ray cannot be enabled unless the external interlock is closed by connecting J2-11 to J2-12. During high voltage operation, opening the interlock circuit will cause the High Voltage to be disabled. Interlock status indication via RS-232 interface at J3.
- **HV ON LAMP RELAY:** When X-ray ON command is enabled a NO and a NC relay contact closure will occur at connector J2. Refer to pin assignments datasheet SHV#128065-001 and specification for contact ratings.
- **OIL TEMPERATURE MONITOR:** Provides remote oil temperature monitor via RS-232 digital interface port at J3 on front cover.
- **PS Fault Indication:** PS Faults an open collector output on J2-1, indicates that a faults has occurred. High = no faults.

- **X-ray On Indication:** X-ray On Signal is an open collector output on J2-14, indicates that a fault has occurred. High = X-ray off

1.4 System Status and Fault Diagnostic Display

If a fault occurs, the power supply will revert to the POWER DOWN mode indicated by extinguishing of X-Ray ON led and via RS-232 as HV OFF. In local mode to reset a fault, the enable (J2-15) must be re-asserted. In Remote mode to reset a fault, a clear command or X-Ray ON command must be sent via RS-232.

- **EXTERNAL INTERLOCK FAULT:** Indicates that the high voltage supply is inhibited by external interlock protection circuitry solely via RS-232 communication as (ARG 8) Open Interlock.
- **OVERVOLTAGE:** Indicates the over voltage protection circuitry has caused the high voltage to turn off. Over voltage protection is internally set to 88kv. This fault is indicated by OV led status on the front cover and via RS-232 as (ARG 3), Over Voltage.
- **OVER CURRENT FAULT:** Indicates the output current has exceeded 1.375ma or if the allowable percentage of error between actual and programmed emission currents is exceeded resulting in the HV to be turned off. This fault is indicated by illumination of OC led status on the front cover and via RS-232 as (ARG 5) Over Current.
- **ARC FAULT:** On the standard unit indicates that an arc has occurred. This fault is indicated by momentary (~ 1 sec) illumination of ARC FLT led status on front cover and via RS-232 as (ARG 1) Arc. Occurrences of three arcs within a period of ten seconds will shutdown the high voltage. This fault is indicated by illumination of ARC FLT led status on front cover and via RS-232 as (ARG 1) Arc. If the one arc shutdown option is ordered one arc will shutdown the high voltage.
- **UNDER VOLTAGE:** Indicates a failure in the voltage regulation circuitry. This fault occurs when there is a lack of output power to maintain regulation and will result in shutdown of the HV. This fault is indicated by illumination of UV led status on the front cover and via RS-232 as (ARG 4) Under Voltage.
- **UNDER CURRENT:** Indicates failure in the current regulation circuitry. This fault occurs when the allowable percentage of error between actual and programmed emission currents is exceeded, due to the actual emission current being less than the programmed level. This fault **does not** shutdown the HV, it is indicated by illumination of UC led status on front cover and via RS-232 as (ARG 6) Under Current.
- **OVER TEMPERATURE:** Indicates that the internal oil temperature has exceeded 66 deg C. This could be either caused by a failure in the customer supplied cooling fan that would cause the oil temperature to exceed 65 deg C or the ambient temperature has exceeded 40 deg C, resulting in shutdown of HV. This fault is indicated by OT led status on the front cover and via RS-232 as (ARG 6) Over Temperature.
- **POWER ON LED:** When input power is applied to the unit it is indicated by the POWER led being illuminated.
- **X-ray On LED:** when the high voltage status is "On" state it is indicated by X-RAY ON led status on the front cover.
- **WATCHDOG TIMER:** Indicates the host computer has lost communication and with the HVPS system for a period greater than ten second. This feature is enabled via RS-232 host command. This fault is indicated via RS-232 as (ARG 5) Watchdog Time-out. See digital manual for details.

1.5 Interpreting the Model Number

The model number of the power supply describes its capabilities. After the series name is:

1. Maximum voltage (in kV).
2. Polarity of the unit: (N) Negative
3. The maximum output (in watts).
4. Options
5. Custom model number

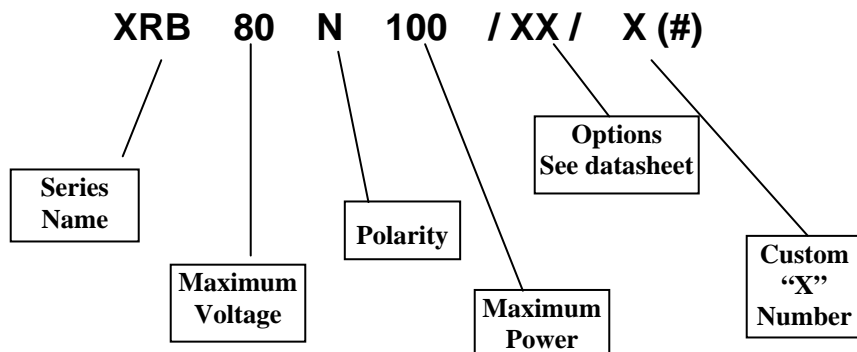

XRB80N100

Chapter 2

INSPECTION & INSTALLATION

Initial inspection and preliminary checkout procedures are recommended. For safe operation, please follow the step-by-step procedures described in Chapter 3, Operating Systems.

2.1 Initial Inspection

Inspect the package exterior for evidence of damage due to handling in transit. Notify the carrier and Spellman immediately if damage is evident. Do not destroy or remove any of the packing material used in a damaged shipment.

After unpacking, inspect the panel and chassis for visible damage.

Fill out and mail the Warranty Registration card accompanying the unit. Standard Spellman MONOBLOCK® Series high voltage power supplies and components are covered by warranty.

2.2 Installation

The unit can be mounted in any position, 8 mounting holes are provided on the bracket shown below. Do not block any of the vents holes in the top cover. See the Operating instructions for vent hole locations and cooling.

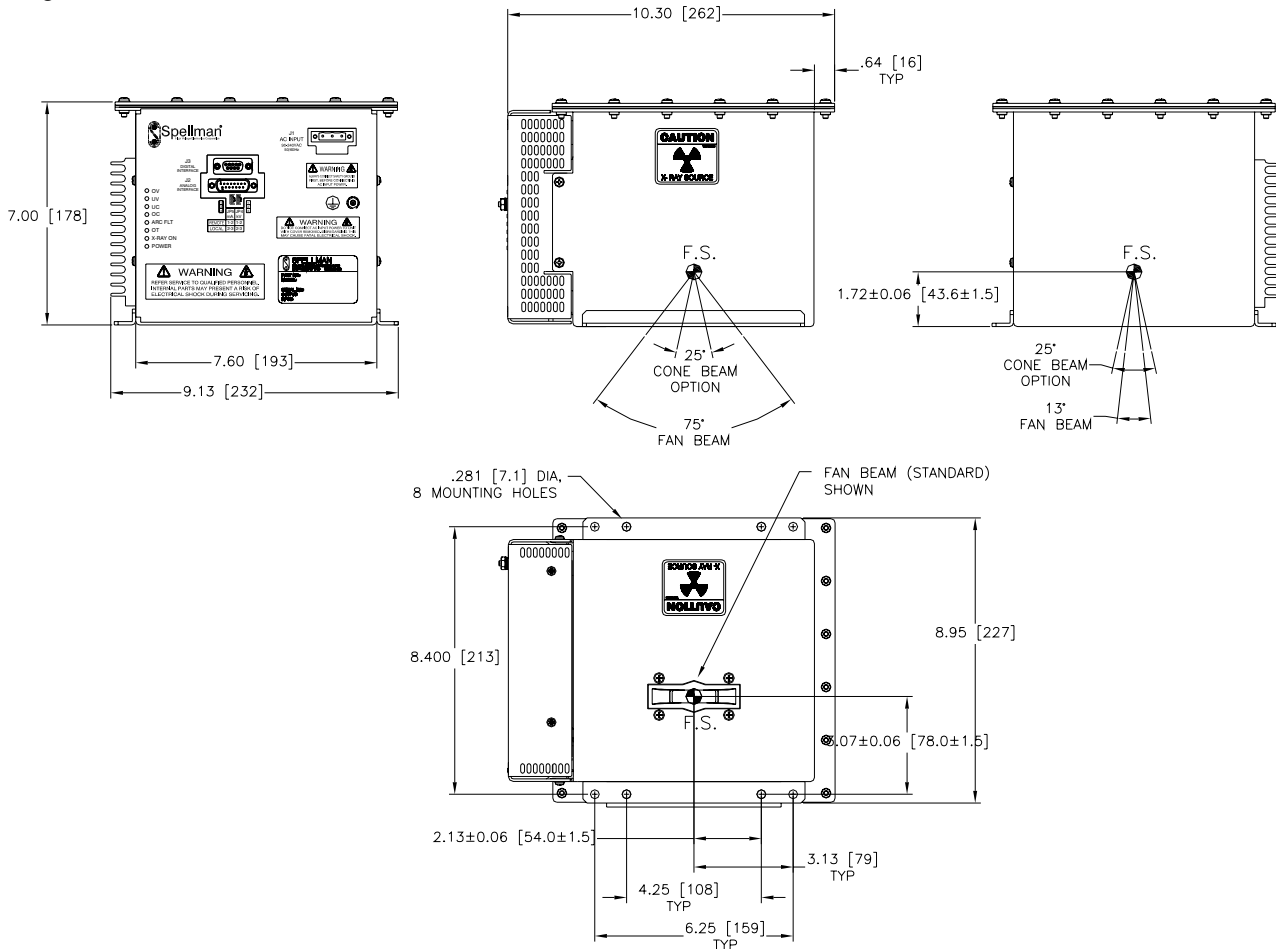

Chapter 3

OPERATING INSTRUCTIONS

3.1 Operation

WARNING

THIS EQUIPMENT GENERATES DANGEROUS VOLTAGES THAT MAY BE FATAL.

PROPER GROUNDING OF ALL HIGH VOLTAGE EQUIPMENT IS ESSENTIAL.



WARNING X-RAY RADIATION EXPOSURE IS HAZARDOUS

Failure to follow these procedures may void the warranty.

Check the input voltage rating on the nameplate of the supply and make certain that this is the rating of the available power source. Spellman MONOBLOCK® XRB80N100 operates on 90-264VAC, single phase 50 or 60Hz.

Bellows Vent holes:

Do not block or insert anything into the vent holes located on top cover as shown. These nine holes provide venting for the internal bellows that is used to compensate for the expansion of the oil as the oil temperature varies.

Do not block any vents holes on the cover

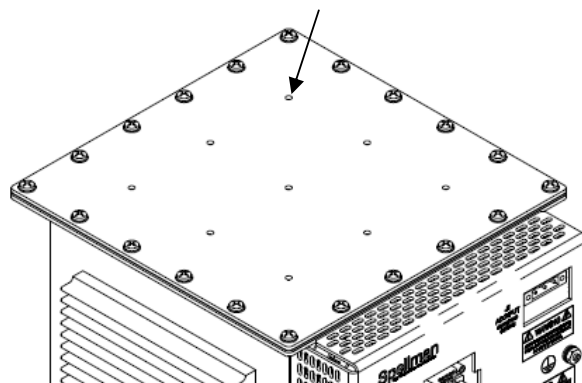

Cooling:

A customer supplied 100 CFM fan should be used to maintain safe operating temperature for MONOBLOCK® X-ray generator. The air flow should be direct at the heat sink on the side of the unit and at the side of the control board compartment. During operation the internal oil temperature should be below 60 deg C and should not exceed 65 deg C. See below Figure for fan location.

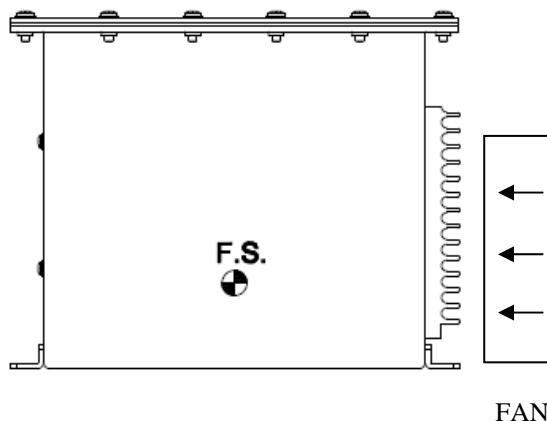

BEFORE CONNECTING THE POWER SUPPLY TO THE AC LINE, FOLLOW THIS PROCEDURE.

1) PROPER GROUNDING TECHNIQUES: The chassis of the X-Ray Generator must be grounded, by using the ground connected to the ground stud located on the cover of the Inverter/Control Assembly.

WARNING

2) ENSURE THAT THE EXIT PORT IS PROPERLY MATED TO COLLIMATOR OR SATISFACTORILY SHIELDED WITH LEAD PLUG TO LIMIT EXPOSURE TO LEAKAGE RADIATION.

X-ray Safety Procedures must be followed when testing this unit. The XRB80N100 is capable of producing Lethal Voltages and X-ray Radiation. Only proceed with operation of the HVPS after

- a) consulting with the Manufacturer and verification of X-Ray setup for the proper precautions.
- b) reading this entire document.

NEVER OPERATE THIS UNIT WITH AN OPEN X-RAY EXIT PORT.

It is recommended not to allow leakage radiation exceeding 0.5mR/hr at 5cm from any surface of the MONOBLOCK®.

3.2 Signal and Power Interface Connections

- 1) Connect Ground wire to the stud located on the cover of the Inverter/Control Assembly marked Ground.
- 2) If operating in Remote Mode connect digital signal interface RS-232 communication cable from the host computer to the J3 connector on Control Assembly.
- 3) Close external Interlock by connecting J2-11 to J2-12 through a dry contact. See Figure 3.1 for wiring diagram and specifications.
- 4) Connect 90 - 264VAC line to J1 use Phoenix contact connector block # 1805990(not provided) Pin 1= earth Pin 2 =Line and Pins 3= Neutral. Make sure AC line voltage is OFF when connecting to the unit.
- 5) Determine unit's idle time and refer to Table 2 for seasoning procedure. If in doubt, use the longest seasoning schedule.

3.3 Local Mode (Analog control)

- 1) To operate in Local mode, position jumpers for JP4 and JP5 on the front cover in the 2-3 position as per table on the front cover.
- 2) Program kV output value by providing 0-9.00V (0-80kV) to J2-3(reference to signal ground J2-9).
- 3) Program ma output value by providing 0-9.00V (0-1.25mA) to J2-2 (reference to signal ground J2-9).

See Figure 3.2 for wiring diagram and specifications.

3.4 Local Mode (Analog monitors)

- 1) Monitor kV output by measuring J2-8(reference to signal ground J2-10), 0-9.00v (0-80kV).
- 2) Monitor ma output by measuring J2-6 (reference to signal ground J2-10), 0-9.00V (0-1.25mA)

See Figure 3.3 for wiring diagram and specifications.

3.5 Local Mode (Analog enable)

- 1) In local mode, to enable X-ray On connect J2-13 to J2-15 through a dry contact. The external interlock must also be close for the X-ray to enable.

See Figure 3.4 for wiring diagram and specifications.

3.6 Remote Mode (Digital control)

- 1) To operate in Remote mode, position jumpers for JP4 and JP5 in the 1-2 position as per table on front cover.

G.U.I and operation instruction

- 2) Install the G.U.I software to the host computer (See CD with GUI).
- 3) Start the G.U.I.
- 4) Read agreement then click AGREE.
- 5) Operate the unit using GUI. For instruction on GUI operation, see the "XRB80N100 GUI INSTRUCTION" document provided on with the GUI on the CD.

3.7 X-ray Tube Seasoning Process

Caution: To prevent premature degradation of the X-ray tube, it is highly recommended to run the seasoning process if the unit has not been turned on for more than 3 days. See Table 2.

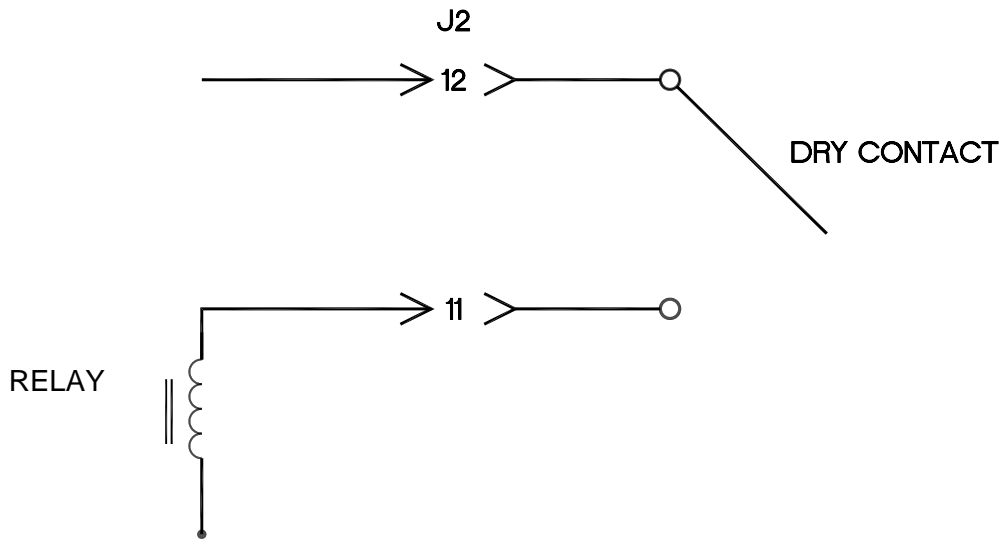

Figure 3.1 Interlock Logic Control

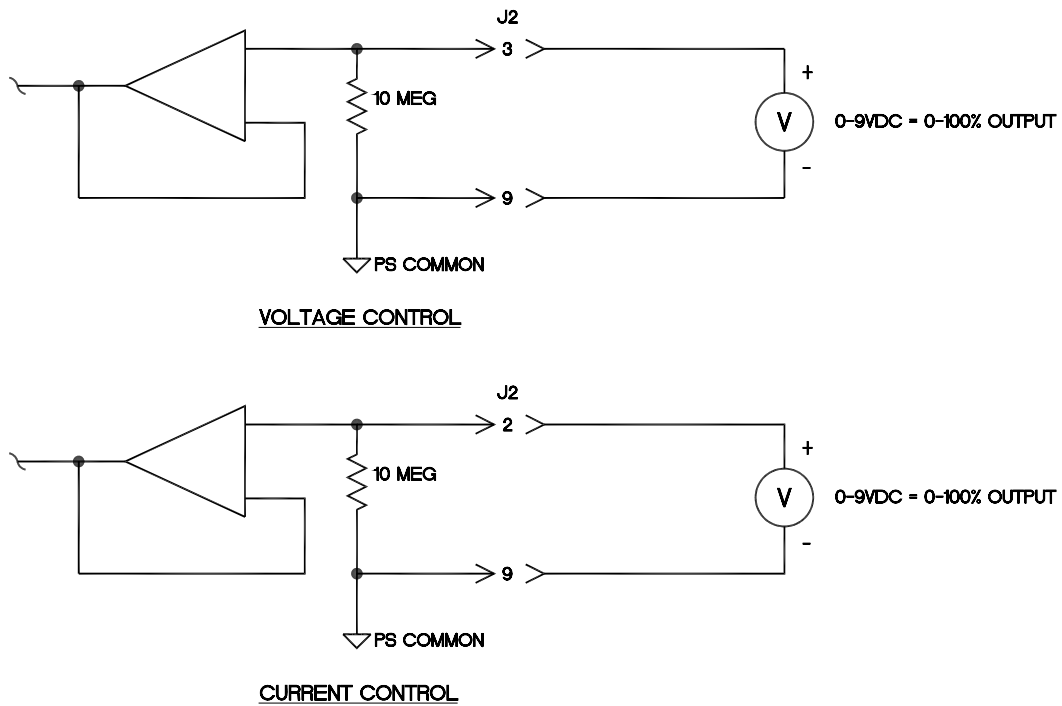

Figure 3.2 Local Programming via External Voltage Source

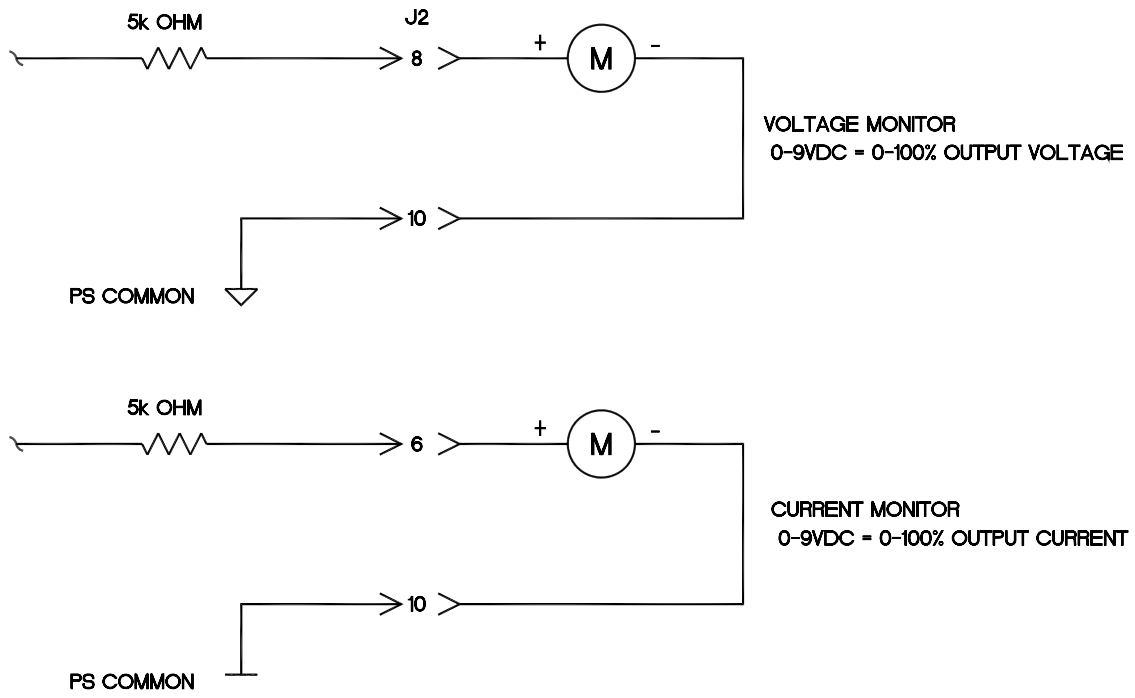

Figure 3.3 Remote Monitoring

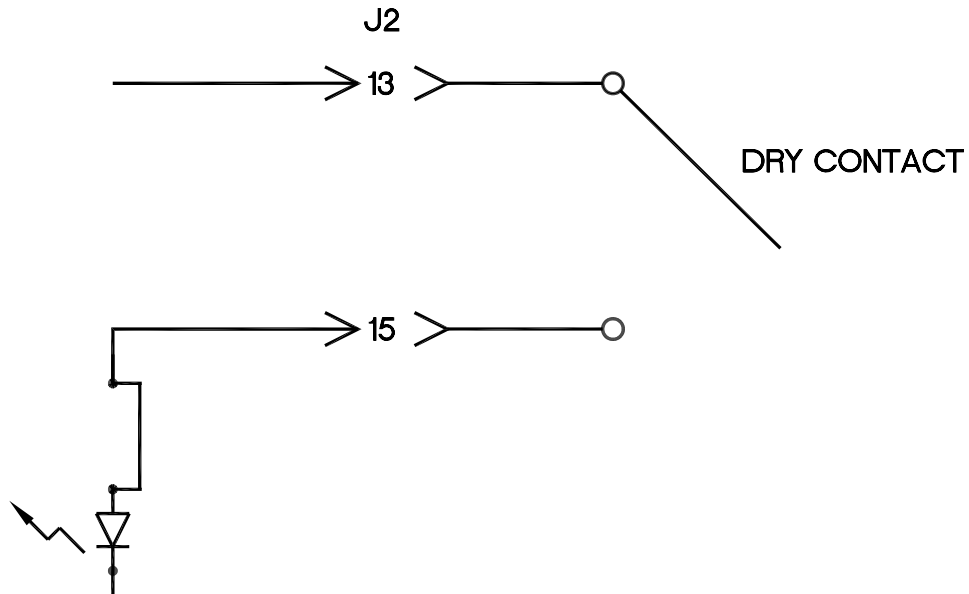

Figure 3.4 Local Enable Logic Control

Chapter 4

DIAGNOSTICS

Fault/Symptom	Possible Cause
OV led illuminated and Over voltage fault at RS-232 resulting in HV Status Off.	kV programming set greater than 80kV.
UV led illuminated and Under Voltage fault at RS-232 resulting in HV Status Off.	AC input voltage lower than minimum specified.
OC led illuminated and Over Current fault at RS-232 resulting in HV Status Off.	mA programming greater than 1.25mA.
UC led illuminated and Under current fault at RS-232 resulting in HV Status Off.	kV programming is less than 40kV or AC input voltage below spec.
OT led illuminated and Over temperature fault at RS-232 resulting in HV Status Off.	Internal oil temperature is above 65 deg C, could be caused by operation at ambient temperature greater than 40°C or failure of a customer supplied cooling fan.
ARC FLT led momentarily illuminated and a momentary Arc fault at RS-232 resulting in HV Status staying ON.	Occurrence of tube arc. Refer to tube re-seasoning procedure Table 2 and idle times.
ARC FLT led illuminated and Arc fault at RS-232 resulting in HV Status OFF	At least three arcs occurred in a ten second period causing shutdown. Clear fault and send X-ray command. Refer to tube re-seasoning procedure Table 2 and idle times. If problem continues contact Spellman service department.
Unit will not Enable	Interlock open

TABLE 1

Chapter 5

FACTORY SERVICE

5.1 Warranty Repairs

During the Warranty period, Spellman will repair all units free of charge. The Warranty is void if the unit is worked on by other than Spellman personnel. See the Warranty in the rear of this manual for more information. Follow the return procedures described in Section 5.2. The customer shall pay for shipping to and from Spellman.

5.2 Factory Service Procedures

Spellman has a well-equipped factory repair department. If a unit is returned to the factory for calibration or repair, a detailed description of the specific problem should be attached.

For all units returned for repair, please obtain an authorization to ship from the Customer Service Department, either by phone or mail prior to shipping. When you call, please state the model and serial numbers, which are on the plate on the rear of the power supply, and the purchase order number for the repair. A Return Material Authorization Code Number (RMA Number) is needed for all returns. This RMA Number should be marked clearly on the outside of the shipping container. Packages received without an RMA Number will be returned to the customer. The Customer shall pay for shipping to and from Spellman.

A preliminary estimate for repairs will be given by phone by Customer Service. A purchase order for this amount is requested upon issuance of the RMA Number. A more detailed estimate will be made when the power supply is received at the Spellman Repair Center. In the event that repair work is extensive, Spellman will call to seek additional authorization from your company before completing the repairs.

5.3 Ordering Options and Modifications

Many of the options can be retrofitted into Spellman's power supplies by our factory. For prices and arrangements, contact the Spellman Sales Department.

5.4 Shipping Instructions

All power supplies returned to Spellman must be sent shipping prepaid. Pack the units carefully and securely in a suitable container, preferably in the original container, if available. The power supply should be surrounded by at least four inches of shock absorbing material. Please return all associated materials, i.e. high voltage output cables, interconnection cables, etc., so that we can examine and test the entire system.

All correspondence and phone calls should be directed to:

Spellman High Voltage Electronics Corp.

475 Wireless Boulevard

Hauppauge, New York 11788

TEL: (631) 630-3000 FAX: (631) 435-1620

E-Mail: sales@Spellmanhv.com

RE-SEASONING PROCESS

for

XRB80N100

Parameters	Step 1	Step 2	Step 3	Step 4	Step 5	Step 6	Step 7	Step 8	Step 9	Step 10
Voltage (kV)	40	45	50	55	60	65	70	70	75	80
Current (uA)	250	400	550	700	850	1000	1150	1250	1250	1250
For units with idle time >3 months	5 min	5 min	5 min	5 min	5 min	5 min	5 min	5 min	5 min	5 min
For units with idle time of 1-3 months	60 sec	60 sec	60 sec	60 sec	60 sec	60 sec	60 sec	60 sec	60 sec	60 sec
For units with idle time of 3-30 days	30 sec	30 sec	30 sec	30 sec	30 sec	30 sec	30 sec	30 sec	30 sec	30 sec

TABLE 2

SPELLMAN HIGH VOLTAGE ELECTRONICS

WARRANTY

Spellman High Voltage Electronics ("**Spellman**") warrants that all power supplies it manufactures will be free from defects in materials and factory workmanship, and agrees to repair or replace, without charge, any power supply that under normal use, operating conditions and maintenance reveals during the warranty period a defect in materials or factory workmanship. The warranty period is twelve (12) months from the date of shipment of the power supply. With respect to standard SL power supplies (not customized) the warranty period is thirty-six (36) months from the date of shipment of the power supply.

This warranty does not apply to any power supply that has been:

- Disassembled, altered, tampered, repaired or worked on by persons unauthorized by **Spellman**;
- subjected to misuse, negligent handling, or accident not caused by the power supply;
- installed, connected, adjusted, or used other than in accordance with the original intended application and/or instructions furnished by **Spellman**.

THE FOREGOING WARRANTY IS IN LIEU OF ALL OTHER WARRANTIES, EXPRESS OR IMPLIED, INCLUDING THOSE OF MERCHANTABILITY OR FITNESS FOR A PARTICULAR PURPOSE.

The buyer's sole remedy for a claimed breach of this warranty, and **Spellman's** sole liability is limited, at **Spellman's** discretion, to a refund of the purchase price or the repair or replacement of the power supply at **Spellman's** cost. The buyer will be responsible for shipping charges to and from **Spellman's** plant. The buyer will not be entitled to make claim for, or recover, any anticipatory profits, or incidental, special or consequential damages resulting from, or in any way relating to, an alleged breach of this warranty.

No modification, amendment, supplement, addition, or other variation of this warranty will be binding unless it is set forth in a written instrument signed by an authorized officer of **Spellman**.

Factory Service Procedures

For an authorization to ship contact **Spellman's** Customer Service Department. Please state the model and serial numbers, which are on the plate on the rear panel of the power supply and the reason for return. A Return Material Authorization Code Number (RMA number) is needed from **Spellman** for all returns. The RMA number should be marked clearly on the outside of the shipping container. Packages received without an RMA Number may delay return of the product. The buyer shall pay shipping costs to and from **Spellman**. Customer Service will provide the Standard Cost for out-of-warranty repairs. A purchase order for this amount is requested upon issuance of the RMA Number (in-warranty returns must also be accompanied by a "zero-value" purchase order). A more detailed estimate may be made when the power supply is received at **Spellman**. In the event that the cost of the actual repair exceeds the estimate, **Spellman** will contact the customer to authorize the repair.

Factory Service Warranty

Spellman will warrant for three (3) months or balance of product warranty, whichever is longer, the repaired assembly/part/unit. If the same problem shall occur within this warranty period **Spellman** shall undertake all the work to rectify the problem with no charge and/or cost to the buyer. Should the cause of the problem be proven to have a source different from the one that has caused the previous problem and/or negligence of the buyer, **Spellman** will be entitled to be paid for the repair.

Spellman Worldwide Service Centers

For a complete listing of **Spellman's** Global Service facilities please go to:
<http://www.spellmanhv.com/customerservice/service.asp>

80KV XRB Digital Interface

Serial – RS-232



Copyright © 2009, Spellman High Voltage Electronics Corporation. All Rights Reserved. This information contained in this publication is derived in part from proprietary and patent data. This information has been prepared for the express purpose of assisting operating and maintenance personnel in the efficient use of the model described herein, and publication of this information does not convey any right to reproduce it or to use it for any purpose other than in connection with installation, operation, and maintenance of the equipment described.

118096-001 REV B

USA CHINA EUROPE JAPAN MEXICO

Changes

REVISION	DATE	DESCRIPTION
1	6/28/08	Draft version
2	7/10/08	Changed communication protocol
3	7/16/08	Minor Corrections
4	1/21/09	Add baud rate command
5	1/26/09	Add checksum example.
B	8/21/09	Correct VB code for calculating checksum

Table Of Contents

1.0 Scope	4
2.0 Functional Description	4
3.0 Getting Started - Interface Wiring and Pin-outs	4
3.1 RS232 Interface	4
3.4 RS-232 Cabling.....	5
4.0 Getting Started - Software	6
4.1 RS-232	6
5.0 Serial Commands – RS-232	8
5.1 Serial Interface Protocol	8
5.2 Command Arguments	8
5.3 Checksums	8
5.4 Command Overview	10
5.5 Response Overview	11
5.6 Command Structure	13
5.7 Spellman Test Commands	35
6.0 SerialCommand Handling	35
6.1 Command Time out	35
6.2 Buffer Flushing	35
6.3 Hand shaking	35

WARNING

THIS EQUIPMENT GENERATES DANGEROUS VOLTAGES THAT MAY BE FATAL. PROPER GROUNDING OF ALL HIGH VOLTAGE EQUIPMENT IS ESSENTIAL. SEE 80kv MONOBLOCK OWNERS MANUAL FOR PROPER GROUNDING TECHNIQUE AND SAFETY PRECAUTIONS BEFORE APPLYING AC INPUT POWER TO THE XRB UNIT.

TO PREVENT DAMAGE TO THE HOST COMPUTER THE COMPUTER SHOULD BE GROUNDED TO THE SAME GROUND AS THE UUT.

This unit is capable of producing X-ray radiation, please proceed only after proper precautions have been taken to prevent X-ray exposure.

1.0 SCOPE

This document applies to the communications interfaces on the XRB, assembly 460162.

2.0 FUNCTIONAL DESCRIPTION

The XRB provides 1 type of digital communications interface:

- RS-232 on J3

3.0 GETTING STARTED - INTERFACE WIRING AND PIN-OUTS

3.1 RS232 INTERFACE

The RS232C interface has the following attributes:

- 115K bits per second
- No Parity
- 8 Data Bits
- 1 Stop Bit
- No handshaking
- DB-9 connector as shown

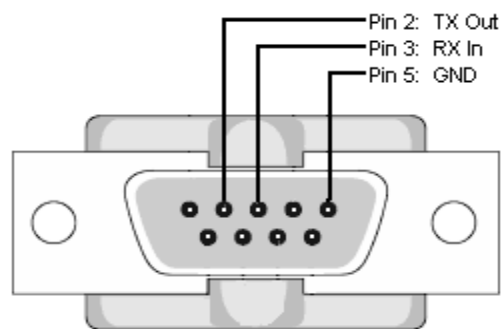

SIC Serial Port: DB-9 Male

Figure 1 – J3, RS-232 DB-9M pinout (front view)

PIN	DESCRIPTION
1	-
2	Tx Out
3	Rx In
4	-
5	Ground
6	-
7	-
8	-
9	-

3.4 RS-232 CABLING

A standard shielded RS-232 cable is used to connect the XRB serial port to the serial port on a standard personal computer. Please refer to the following chart.

PC to XRB Board Cable Details	
PC Connector (DB-9 Female)	XRB Connector (DB-9 Male)
Pin 2: RX In	Pin 2: TX Out
Pin 3: TX Out	Pin 3: RX In
Pin 5: Ground	Pin 5: Ground

4.0 GETTING STARTED – SOFTWARE

The following sections detail how to create software to interface to the XRB communications interfaces.

4.1 RS-232

The RS-232 interface makes use of a standard ‘command/response’ communications protocol. See section 5.0 for the syntax of the serial interface protocol. The programmer should also review section 4.3 for programming considerations for the RS-232 interface.

All software that addresses the RS-232 interface must adhere to the following parameters:

- A default Baud rate of 115.2K bps
- No Parity
- 8 Data Bits
- 1 Stop Bit
- No handshaking

4.1.1 Enabling Communications Objects in Visual Basic for RS-232

Communications in Microsoft Visual Basic 6.0 are directed to a control that abstracts the port. In the case of serial and USB we need Microsoft Comm Control 6.0. To enable this in your VB 6 project, go to:

Project -> Components

Then in the list make sure that Microsoft Comm Control 6.0 has a check next to it. The Comm Control Object should then appear in your toolbox. It will have an icon of a telephone and will be named: MSComm. This can be dragged and dropped into your application. You will then need to set the object’s properties.

4.1.2 Configuring Communications in Visual Basic for RS-232

In order to configure the MSComm Object, first you must initialize it in the Object properties:

Settings	115200,n,8,1
Handshaking	0 – comNone

The application can be set to either default to a specific COM Port or the End User can be allowed to choose one for the particular PC.

For the "Default" scenario, include the following commands in the Form_Load() routine:

```
MSComm1.CommPort = portNumber  
MSComm1.PortOpen = True
```

5.0 SERIAL COMMANDS – RS-232

5.1 SERIAL INTERFACE PROTOCOL

Serial communications will use the following protocol:

There are two categories of commands from the host computer to the tank.

1. Commands that have an argument.
2. Commands that do not have an argument.

The syntax of commands that have an argument is:

<STX>CMD<SP>ARG;<CSUM><CR><LF>

The syntax of commands that do not have an argument is:

<STX>CMD;<CSUM><CR><LF>

The specification of the above symbols is as follows:

<STX>	= 1 ASCII 0x02 Start of Text character
<CMD>	= 3 - 4 ALPHA ASCII characters representing the command ID
<SP>	= 1 ASCII 0x20 character
<ARG>	= Command Argument
<;>	= 1 ASCII 0x3B semicolon character 0x3B
<CSUM>	= Checksum (see section 5.3 for details)
<CR>	= Carriage return character 0x0D.
<LF>	= Line feed character 0x0A

5.2 COMMAND ARGUMENTS

The format of the numbers is a variable length string. To represent the number 42, the string '42', '042', or '0042' can be used. This being the case, commands and responses that carry data are variable in length.

5.3 CHECKSUMS

The checksum is computed as follows:

- Add the <CMD>, <;>, and <ARG> bytes excluding the <STX> byte into a 16 bit (or larger) word. The bytes are added as unsigned integers.
- Take the 2's compliment (negate it) and add the value of 1 to the resulting value.
- Truncate the result down to the eight least significant bits.
- Clear the most significant bit (bit 7) of the resultant byte, (bitwise AND with 0x7F).

- Set the next most significant bit (bit 6) of the resultant byte (bitwise OR with 0x40).

Using this method, the checksum is always a number between 0x40 and 0x7F. The checksum can never be confused with the <STX> or <ETX> control characters, since these have non-overlapping ASCII values.

If the DSP detects a checksum error, the received message is ignored – no acknowledgment or data is sent back to the host. A timeout will act as an implied NACK.

CheckSum Calculate Example for VREF command:

VREF<SP>4095; = 0x260H – total sum in Hex.
 = 0xD9FH – negate.
 = 0xDA0H – add one.
 = 0xA0H – truncate down to 8 least significant bits.
 = 0x20H – clear bit 7.
 = 0x60H – set bit 6.

CheckSum = 0x60H

The following is sample code, written in Visual Basic, for the generation of checksums:

```
Public Function ProcessOutputString(outputString As String) As String

Dim i As Integer
Dim CSb1 As Integer
Dim CSb2 As Integer
Dim CSb3 As Integer
Dim CSb$
Dim X

X = 0
For i = 1 To (Len(outputString)) 'Starting with the CMD character
X = X + Asc(Mid(outputString, i, 1)) 'adds ascii values together
Next i

CSb1 = 256 - X
CSb2 = 127 And (CSb1) 'Twos Complement
CSb3 = 64 Or (CSb2) 'OR 0x40
CSb$ = Chr(Val("&H" & (Hex(CSb3))))
ProcessOutputString = Chr(2) & outputString & CSb$ & Chr(13) & Chr(10)

End Function
```

5.4 COMMAND OVERVIEW

Command Name	<CMD>	<ARG>	RANGE
Program kV	VREF	1-4 ASCII	0-4095
Program mA	IREF	1-4 ASCII	0-4095
Request kV Sepoint	VSET	None	-
Request mA Sepoint	ISET	None	-
Request kV Monitor	VMON	None	-
Request mA Monitor	IMON	None	-
Request Filament Monitor	FMON	None	-
Turn XRAY On/Off	ENBL	1 ASCII	0-1
Enable Comm Watchdog	WDTE	1 ASCII	0-1
Tickle Comm Watchdog	WDTT	None	-
Reset Faults	CLR	None	-
Request Faults	FLT	None	-
Read XRAY Status	STAT	None	-
Request Software Version	FREV	None	-
Request Voltage Scaling	SLVR	None	-
Request Current Scaling	SLIR	None	-
Request Model Number	MODR	None	-
Request Hardware Version	HWVR	None	-
Request Software Build Version	SOFT	None	-
Request -15V LVPS	LVPS	None	-
Request Tank Temperature	TEMP	None	-
Program Baud Rate	BAUD	1	1-2

5.5 RESPONSE OVERVIEW

The command responses will follow the same format as outlined above in section 5.1. This list is comprised of Commands with complex responses only. Commands using a simple response will use the <;> character (ASCII 0x3B) as a “Success” response. These responses will be 5 ASCII characters in length.

Response Name	<CMD>	Response
Request kV Monitor	VMON	6-9
Request mA Monitor	IMON	6-9
Request kV Setpoint	VSET	6-9
Request mA Setpoint	ISET	6-9
Request Filament Monitor	FMON	6-9
Request Faults	FLT	13
Read XRAY Status	STAT	6
Request Software Version	FREV	16
Request Voltage Scaling	SLVR	9
Request Current Scaling	SLIR	9
Request Model Number	MODR	6-15
Request Hardware Version	HWVR	8
Request Software Build Version	SOFT	9-10
Request -15V LVPS	LVPS	6-9
Request Tank Temperature	TEMP	6-9

5.6 COMMAND STRUCTURE

5.6.1 Program kV

Description:

The host requests that the firmware change the setpoint of kV.

Direction:

Host to supply

Syntax:

<STX><VREF><SP><ARG><;><CSUM><CR><LF>

Where:

<ARG> = 0 - 4095 in ASCII format

Example:

<STX><VREF><SP><4095><;><CSUM><CR><LF>

Response:

<STX><;><CSUM><CR><LF>

5.6.2 Program mA

Description:

The host requests that the firmware change the setpoint of mA.

Direction:

Host to supply

Syntax:

```
<STX><IREF><SP><ARG><;><CSUM><CR><LF>
```

Where:

<ARG> = 0 - 4095 in ASCII format

Example:

```
<STX><IREF><SP><4095><;><CSUM><CR><LF>
```

Response:

```
<STX><;><CSUM><CR><LF>
```

5.6.3 Request kV Monitor

Description:

The host requests that the firmware report kV monitor.

Direction:

Host to supply

Syntax:

<STX><VMON><;><CSUM><CR><LF>

Example:

<STX><VMON><;><CSUM><CR><LF>

Response:

<STX>< ARG><;><CSUM><CR><LF>

Where:

<ARG>=0-4095 in ASCII format representing unscaled value.

Example:

<STX><4095><;><CSUM><CR><LF>

5.6.4 Request kV Setpoint

Description:

The host requests that the firmware report kV setpoint.

Direction:

Host to supply

Syntax:

<STX><VSET><;><CSUM><CR><LF>

Example:

<STX><VSET><;><CSUM><CR><LF>

Response:

<STX>< ARG><;><CSUM><CR><LF>

Where:

<ARG>=0-4095 in ASCII format representing unscaled value.

Example:

<STX><4095><;><CSUM><CR><LF>

5.6.5 Request mA Setpoint

Description:

The host requests that the firmware report mA setpoint.

Direction:

Host to supply

Syntax:

<STX><ISET><;><CSUM><CR><LF>

Example:

<STX><ISET><;><CSUM><CR><LF>

Response:

<STX>< ARG><;><CSUM><CR><LF>

Where:

<ARG>=0-4095 in ASCII format representing unscaled value.

Example:

<STX><4095><;><CSUM><CR><LF>

5.6.6 Request mA Monitor

Description:

The host requests that the firmware report mA monitor.

Direction:

Host to supply

Syntax:

<STX><IMON><;><CSUM><CR><LF>

Example:

<STX><IMON><;><CSUM><CR><LF>

Response:

<STX>< ARG><;><CSUM><CR><LF>

Where:

<ARG>=0-4095 in ASCII format representing unscaled value.

Example:

<STX><4095><;><CSUM><CR><LF>

5.6.7 Request Filament Monitor

Description:

The host requests that the firmware report Filament monitor.

Direction:

Host to supply

Syntax:

<STX><FMON><;><CSUM><CR><LF>

Example:

<STX><FMON><;><CSUM><CR><LF>

Response:

<STX>< ARG><;><CSUM><CR><LF>

Where:

<ARG>=0-4095 in ASCII format representing unscaled value.

Example:

<STX><4095><;><CSUM><CR><LF>

5.6.8 Turn XRAYs On/Off

Description:

The host requests that the firmware to turn XRAY On/Off.

Direction:

Host to supply

Syntax:

<STX><ENBL><SP><ARG><;><CSUM><CR><LF>

Where:

<ARG> 1 = XRAY On, 0 = XRAY Off in ASCII format

Example:

<STX><ENBL><SP><1><;><CSUM><CR><LF>

Response:

<STX><;><CSUM><CR><LF>

5.6.9 Enable Commuunication Watchdog

Description:

The host requests that the firmware to enable communication watchdog.

Direction:

Host to supply

Syntax:

<STX><WDTE><SP><ARG><;><CSUM><CR><LF>

Where:

<ARG> 1 = Enable Watchdog, 0 = Disable Watchdog

Example:

<STX><WDTE><SP><1><;><CSUM><CR><LF>

Response:

<STX><;><CSUM><CR><LF>

5.6.10 Tickle Communication Watchdog

Description:

The host requests that the firmware reset communication watchdog timer.

Direction:

Host to supply

Syntax:

<STX><WDTT><;><CSUM><CR><LF>

Example:

<STX><WDTT><;><CSUM><CR><LF>

Response:

<STX><;><CSUM><CR><LF>

5.6.11 Reset Faults

Description:

The host requests that the firmware resets all Fault messages and indicators.

Syntax:

<STX><CLR><;><CSUM><CR><LF>

Example:

<STX><CLR><;><CSUM><CR><LF>

Response:

<STX><;><CSUM><CR><LF>

5.6.12 Request Faults

Description:

The host requests that the firmware report Faults.

Direction:

Host to supply

Syntax:

<STX><FLT><;><CSUM><CR><LF>

Example:

<STX><FLT><;><CSUM><CR><LF>

Response:

<STX><ARG1><ARG2><ARG3><ARG4><ARG5><ARG6><ARG7>
<ARG8><;><CSUM><CR><LF>

Where:

<ARGx> 1 = Fault, 0 = No Fault in ASCII format

ARG1 = ARC

ARG2 = Over Temperature

ARG3 = Over Voltage

ARG4 = Under Voltage

ARG5 = Over Current

ARG6 = Under Current

ARG7 = Watchdog Time-out

ARG8 = Open Interlock

Example:

<STX><10001001><;><CSUM><CR><LF>

5.6.13 Request XRAY Status

Description:

The host requests that the firmware read the XRAY status.

Direction:

Host to supply

Syntax:

<STX><STAT><;><CSUM><CR><LF>

Example:

<STX><STAT><;><CSUM><CR><LF>

Response:

<STX><ARG><;><CSUM><CR><LF>

Where ARG is status. A 1 indicates XRAY On. A 0 indicates XRAY Off.

Example:

<STX><1><;><CSUM><CR><LF>

5.6.14 Request DSP Software Part Number/Version

Description:

The host requests that the firmware sends the DSP firmware.

Direction:

Host to supply

Syntax:

<STX><FREV><;><CSUM><CR><LF>

Example:

<STX><FREV><;><CSUM><CR><LF>

Response:

<STX>< ARG><;><CSUM><CR><LF>

Where:

<ARG> consists of eleven ASCII characters representing the current firmware part number/version. The format is SWM9999-999.

Example:

<STX><SWM9999-999><;><CSUM><CR><LF>

5.6.15 Request Voltage Scaling

Description:

The host requests requests that the firmware send the current unit voltage scaling.

Direction:

Host to supply

Syntax:

<STX><SLVR><;><CSUM><CR><LF>

Example:

<STX><SLVR><;><CSUM><CR><LF>

Response:

<STX>< ARG><;><CSUM><CR><LF>

Where:

ARG = KV scaling (8889 = 88.89 kV)

Example:

<STX><8889><;><CSUM><CR><LF>

5.6.16 Request Current Scaling

Description:

The host requests requests that the firmware send the current unit current scaling.

Direction:

Host to supply

Syntax:

<STX><SLIR><;><CSUM><CR><LF>

Example:

<STX><SLIR><;><CSUM><CR><LF>

Response:

<STX>< ARG><;><CSUM><CR><LF>

Where:

ARG = mA scaling (1388 = 1.388 mA)

Example:

<STX><1388><;><CSUM><CR><LF>

5.6.17 Request Model Number

Description:

The host requests that the firmware sends the unit model number

Direction:

Host to supply

Syntax:

<STX><MODR><;><CSUM><CR><LF>

Example:

<STX><MODR><;><CSUM><CR><LF>

Response:

<STX>< ARG><;><CSUM><CR><LF>

Where:

<ARG> consists of one to ten ASCII characters representing the model number. The format is XBR80N100 or CB for cone beam option

Example:

<STX><XBR80N100><;><CSUM><CR><LF>

5.6.18 Request Hardware Version

Description:

The host requests that the firmware sends the hardware version.

Direction:

Host to supply

Syntax:

<STX><MODR><;><CSUM><CR><LF>

Example:

<STX><MODR><;><CSUM><CR><LF>

Response:

<STX>< ARG><;><CSUM><CR><LF>

Where:

<ARG> consists of 3 ASCII characters representing the hardware version. The format is ANN, where A is an alpha character and N is a numeric character

Example:

<STX><A01><;><CSUM><CR><LF>

5.6.19 Request Software Build Version

Description:

The host requests that the firmware sends the hardware version.

Direction:

Host to supply

Syntax:

<STX><SOFT><;><CSUM><CR><LF>

Example:

<STX><SOFT><;><CSUM><CR><LF>

Response:

<STX>< ARG><;><CSUM><CR><LF>

Where:

<ARG> consists of four to five ASCII characters representing the current firmware build version. The format is 12345.

Example:

<STX><12345><;><CSUM><CR><LF>

5.6.20 Request –15V LVPS

Description:

The host requests that the firmware report –15V LVPS.

Direction:

Host to supply

Syntax:

<STX><LVPS><;><CSUM><CR><LF>

Example:

<STX><LVPS><;><CSUM><CR><LF>

Response:

<STX><ARG><;><CSUM><CR><LF>

Where:

<ARG>=0-4095 in ASCII format representing unscaled value.

To convert the unscaled value to voltage, use the equation below:

x = unscaled value.

Voltage = $-(3972 - x) * 0.006224$.

Example:

<STX><4095><;><CSUM><CR><LF>

5.6.21 Request Tank Temperature

Description:

The host requests that the firmware sends the tank temperature.

Direction:

Host to supply

Syntax:

<STX><TEMP><;><CSUM><CR><LF>

Example:

<STX><TEMP><;><CSUM><CR><LF>

Response:

<STX><ARG><;><CSUM><CR><LF>

Where:

<ARG>=0-956 in ASCII format representing 0 – 70.036 degrees C.

Example:

<STX><956><;><CSUM><CR><LF>

5.6.22 Program Baud Rate Select

Description:

The host requests that the firmware select a baud rate.

Direction:

Host to supply

Syntax:

<STX><BAUD><SP><ARG><;><CSUM><CR><LF>

Where:

<ARG> = 1 in ASCII format = 115200 Baud

<ARG> = 2 in ASCII format = 9600 Baud

Example:

<STX><BAUD><SP><1><;><CSUM><CR><LF>

Response:

<STX><;><CSUM><CR><LF>

5.7 SPELLMAN RESERVED COMMANDS

- Program Hardware Version (Hardware setup)
- Program Model number(Hardware setup)
- Program Scaling (Hardware setup)
- Program Filament Pre-Heat (Hardware setup)
- Program Ramp Rates (Hardware setup)
- Store A/D Calibration Value (Hardware setup)

Contact Spellman High Voltage for details and the syntax of these commands.

6.0 SERIAL COMMAND HANDLING

6.1 Command Time OutThe host computer should set a serial time out at approximately 100mS. This allows the DSP to process the incoming message, and transmit a response. The DSP will initiate a reply to incoming messages in approximately 1-2mS, with a worst case of 5mS.

6.2 Buffer Flushing

The DSP will flush the incoming serial data buffer every time an STX is received. This provides a mechanism to clear the receive buffer of partial or corrupt messages.

6.3 Handshaking

The only handshaking implemented on the host interface, is built in to the implementation of this protocol. That is, the host must initiate all communications. If the supply receives a program command, an acknowledge message is sent back to the host via the “;” message. If the host does not receive an acknowledge within the time out window, the host should consider the message lost or the device off-line.

Similarly, if the supply receives a request command, the requested data is sent back to the host. If the host does not receive the requested data within the time out window, the host should consider the message lost or the device off-line.

This essentially uses the full-duplex channel in a half-duplex communication mode.