



Spellman's XRBHR (high reliability) Series of Monoblock® X-Ray sources are designed for OEM applications powering their internal Bipolar X-Ray tube at 80kV and 100kV at power levels of 100W, 210W, 350W and 500W. Features such as universal input, compact package size and a standard RS-232 digital interface simplify integration of any XRBHR model into your X-Ray system. Each XRBHR model is available with fan shaped (standard) or cone shaped (optional) beam geometries. Proprietary emission control circuitry provides excellent regulation of X-Ray tube current, along with outstanding stability performance. The XRBHR Series is designed for long field life and comes with a 3 year warranty.

TYPICAL APPLICATIONS

Food Inspection Systems, Fill Level Confirmation Systems, Security Scanning Systems, Industrial NDT Systems, Thickness/Plating Measurement Systems

OPTIONS

- CB** Cone Beam
- .5mm** .5mm focal spot X-Ray tube
- ST-TE**
- RA-SE** See page 4 for Cable Options
- RA-TE**

SPECIFICATIONS

X-Ray Characteristics:

- Focal Spot: 0.8mm (IEC 336) standard
0.5mm (IEC 336) optional
- Beam Filter:
 - Ultem: 1.50mm ±0.15mm
 - Oil: 9.0mm ±0.25mm
 - Glass: 1.7mm ±0.2mm
 - Be: 0.8mm
- Beam Geometry:
 - Fan: Standard. The beam angular coverage will be 90° with the beam plane perpendicular to the X-Ray tube axis and 12° wide (with a 2° tolerance)
 - Cone: Optional. 40° cone beam (with a 2° tolerance)

- **Compact & Lightweight**
- **Universal Input, Power Factor Corrected**
- **Can be Mounted in Any Physical Orientation**
- **Analog Monitoring Interface, Standard RS-232 Digital Interface and Ethernet**
- **Data Logging and Firmware Controlled X-Ray Tube Seasoning**

Input Voltage:

100- 240Vac, ±10%, 50/60 Hertz, .98 power factor

Input Current:

- 100W @ 2A
- 210W @ 4A
- 350W @ 6A
- 500W @ 8A

X-Ray Tube Voltage:

See table. Minimum kV for emission current 35kV

X-Ray Tube Current:

See table. Minimum emission current 150uA

X-Ray Tube Power:

See table

Voltage Regulation:

- Line: ±0.05% of maximum output voltage over a ±10% change of nominal input line voltage
- Load: ±0.1% of maximum rated voltage for 150uA to full rated load change

Voltage Accuracy:

Voltage measured across the X-Ray tube is within ±2% of the programmed value

Voltage Risetime:

Standard ramp time shall be <500ms from 10% to 90% of maximum rated output voltage

Voltage Ripple:

0.5% peak to peak of maximum voltage for frequencies ≤1kHz

Emission Current Parameters

Current Regulation:

- Line: ±0.05% of rated output current over a ±10% change of nominal input line voltage
- Load: ±0.1% of rated output current for a change from 50% to 100% of rated output voltage

Current Accuracy:

Current measured through the X-Ray tube is within ±2% of the programmed value

Current Risetime:

Standard ramp time shall be <500ms from 10% to 90% of maximum rated current

Arc Intervention:

4 arcs in 10 seconds with a 100ms quench/100ms re-ramp = Shutdown

Filament Configuration:

Internal floating AC filament drive with closed loop filament emission control circuitry

Analog Interface:

Ground referenced 0 to 9Vdc for all monitoring signals. Relay contacts and open collector signals for other signals. See analog interface connector pin out table.

Digital Interface:

The RS-232 interface allows for programming of kV, mA output and X-Ray enable. Provides monitoring for kV, mA output and oil temperature.

Operating Temperature:

0°C to +40°C

Storage Temperature:

-40°C to +70°C

Humidity:

10% to 95% relative humidity, non-condensing

Cooling:

X-Ray Tank:

- 100W: Convection/customer supplied forced air so tank is <55°C
- 210W: Externally powered forced air cooling, 24Vdc @ 2A
- 350W: Externally powered forced air cooling with oil pump and heat exchanger, 24Vdc @ 5A
- 500W: Externally powered forced air cooling with oil pump and heat exchanger, 24Vdc @ 5A

Controller: Forced air via internal fan.

Grounding Point:

- M5 ground female thread on tank
- M5 ground stud on control chassis provided

Dimensions:

- X-Ray Tank: see drawings
- 100W/210W Controller: see drawings
- 350W/500W Controller: see drawings

Weight:

- X-Ray Tank:
 - 100W @ 75 lbs. (34kg)
 - 210W @ 75lbs. (34kg)
 - 350W @ 81.5lbs. (37kg)
 - 500W @ 81.5lbs. (37kg)

Controller:

- 100W/210W: 4 pounds (1.18kg)
- 350W/500W: 7 pounds (3.18kg)

Orientation:

Can be mounted in any orientation.

X-Ray Leakage:

Not to be greater than 0.5mR/hr at 5cm outside the external surface.

Regulatory Approvals:

Compliant to EEC EMC Directive. Compliant to EEC Low Voltage Directive. UL/CUL recognized file E235530

MODEL SELECTION TABLE

MODEL	MAX. VOLTAGE	MAX. CURRENT	MAX. POWER
XR B80PN210HR	80kV	5.25mA	210 watts
XR B80PN350HR	80kV	8mA	350 watts
XR B80PN500HR	80kV	8mA	500 watts
XR B100PN100HR	100kV	2mA	100 watts
XR B100PN210HR	100kV	4.2mA	210 watts
XR B100PN350HR	100kV	7mA	350 watts
XR B100PN500HR	100kV	8mA	500 watts

LED INDICATORS

INDICATOR	SIGNAL	CONDITION Illuminated When...	LED COLOR
1	OV Error 6	High kV occurs	Red
2	UV Error 5	Low kV occurs	Red
3	UC Error 4	Low mA occurs	Red
4	OC Error 3	High mA occurs	Red
5	ARC Error 2	Arc fault occurs	Red
6	OT Error 1	Over temperature occurs	Red
7	X-Ray On	X-Rays are being generated	Green
8	Power On	AC input power is present	Green

SMART XR B

The XR BHR has two new digital features: data logging and firmware controlled seasoning.

Data Logging:

Think of this as an "airplane black box". The data logging captures data on fault events and non-fault events. Fault events will turn off the high voltage:

FAULT EVENTS

Temperature	Arc
High Current	Low Voltage
High Voltage	Watchdog
Power Fault	Interlock

The XR BHR stores data 620ms before the event, the event itself and for 620ms after the event. Data is recorded every 20ms (62 samples total) showing:

Anode kV	Cathode kV
Total kV	Total mA
Filament	Temperature

We also log non-fault events, these are changes in set points or state of the unit.

NON FAULT EVENTS

HV On	HV Off
kV Set point	mA Set point
Low Current	Filament Limit Set point
Pre Heat Set point	Line Dip

Fault event data is actual graphical data. Non fault event data is just stored as event type, data and timestamp. We also have a preventative maintenance fault, which throws a non-shutdown fault if the X-Ray tube has been factory installed over 4 years ago or if over 15,000 hours of HV ON is logged.

Firmware Controlled Seasoning:

Every unit comes with an initial seasoning table, or customers can set their own. The XR BHR knows when the unit has been on, when it has been off, hours on the X-Ray tube, etc. As a preventative maintenance feature upon turn on, we review the data and suggest that a particular seasoning protocol be run based upon the actual usage history of the unit. Proper seasoning compliance of the X-Ray tube will help get the longest lifetime.

Power and Interface Connections

AC INPUT—3 PIN PHOENIX CONTACT 1858772

PIN	SIGNAL	PARAMETERS
1	AC Input (high)	100-240Vac (high)
2	Ground	Ground
3	AC Input (neutral)	100-240Vac (neutral)

DC INPUT FOR HEAT DISSIPATION UNIT—4 PIN AMP (210/350/500W) 206060-1

PIN	SIGNAL	DESCRIPTION	PARAMETERS
1	24Vdc	Fan/Pump Power	24Vdc @ 5 amps
2	24Vdc Return		
3	N/C	No Connection	N/C
4	N/C	No Connection	N/C

It is critical to ensure that 24Vdc is supplied to pins 1 and 2

ANALOG INTERFACE—10 PIN PHOENIX CONTACT 1792605

PIN	SIGNAL	PARAMETERS
1	X-Ray Interlock Enable	Apply +24Vdc to enable interlock. Open/removal of +24Vdc will cause X-Ray generation to stop.
2	X-Ray Interlock Enable Return	Ground reference for X-Ray Interlock.
3	Pin removed	N/C
4	kV Monitor	0-10Vdc = 0-100% rated output voltage. Zout = 10kΩ
5	Signal Ground	Signal Ground
6	mA Monitor	0-10Vdc = 0-100% rated output current. Zout = 10kΩ
7	Fault Signal	Open collector, High (Open) = No Fault, 35Vdc @ 10mA maximum
8	HV ON Lamp Relay N/O	N/O dry contacts. 50 volts maximum. Rated for 1 amp or less, 50mA nominal load
9	HV ON Lamp Relay C	Common dry contacts. 50 volts maximum. Rated for 1 amp or less, 50mA nominal load
10	HV ON Lamp Relay N/C	N/C dry contacts. 50 volts maximum. Rated for 1 amp or less, 50mA nominal load

RS-232 DIGITAL INTERFACE—9 PIN MALE D CONNECTOR

PIN	SIGNAL	PARAMETERS
1	N/C	N/C
2	Transmitted Data	Conforms to EIA RS-232-C
3	Received Data	Conforms to EIA RS-232-C
4	N/C	N/C
5	Signal Ground	Signal Ground
6	N/C	N/C
7	N/C	N/C
8	N/C	N/C
9	N/C	N/C

ETHERNET DIGITAL INTERFACE—RJ45 8 PIN FEMALE CONNECTOR

PIN	SIGNAL	PARAMETERS
1	TX +	Transmit Data +
2	TX -	Transmit Data -
3	RX +	Receive Data +
4	N/C	No Connection
5	N/C	No Connection
6	RX -	Receive Data -
7	N/C	No Connection
8	N/C	No Connection

DIMENSIONS: in.[mm]

100/210W CONTROL UNIT

FRONT VIEW

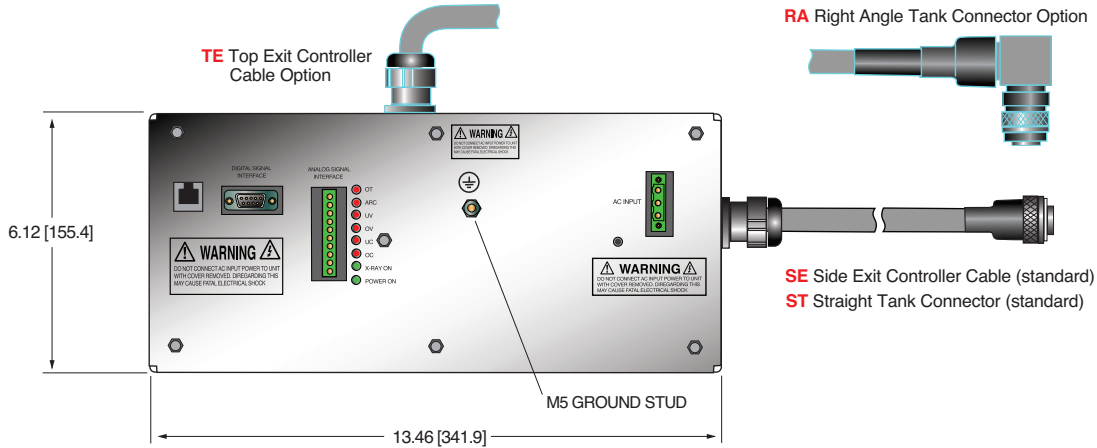

BOTTOM VIEW

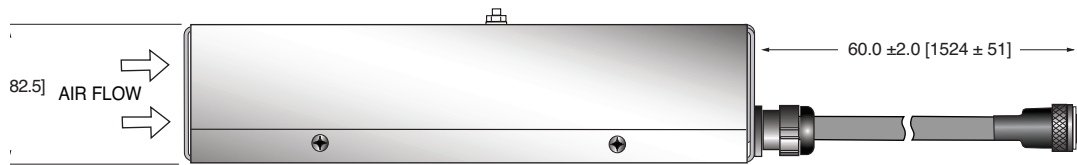

REAR VIEW

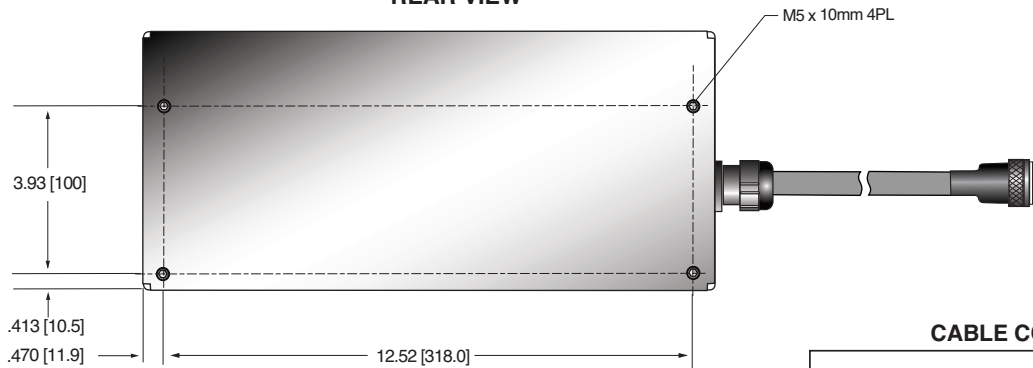

SIDE VIEW



SIDE VIEW

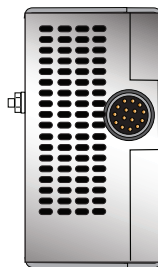

Standard
SE Side Exit shown

CABLE CONFIGURATIONS

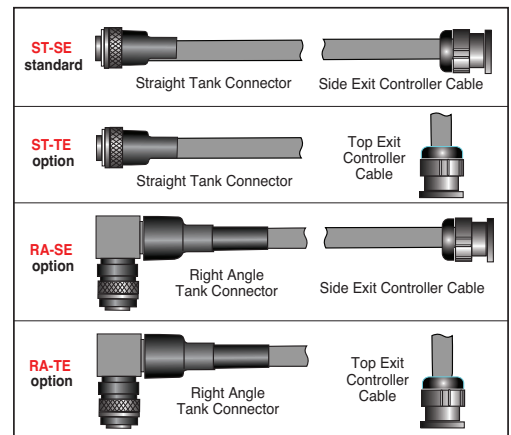

DIMENSIONS: in.[mm]

350/500W CONTROL UNIT

FRONT VIEW

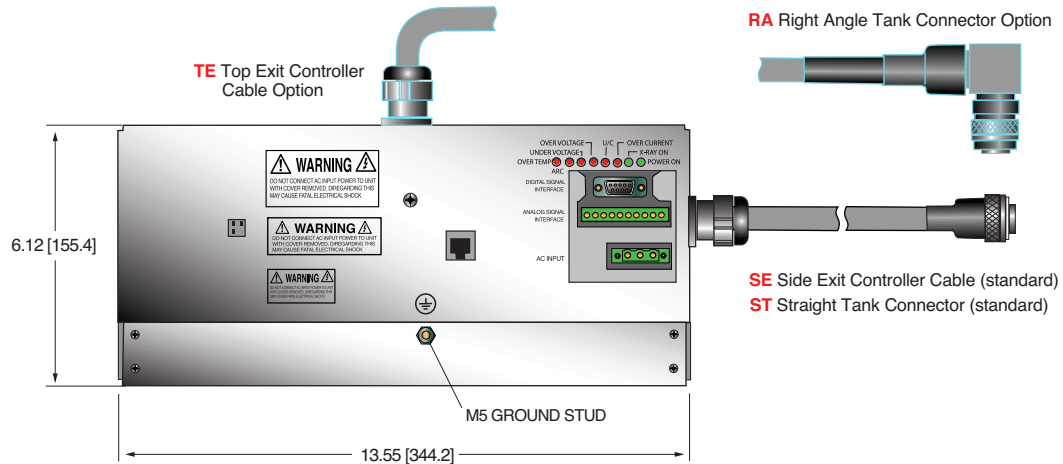

BOTTOM VIEW

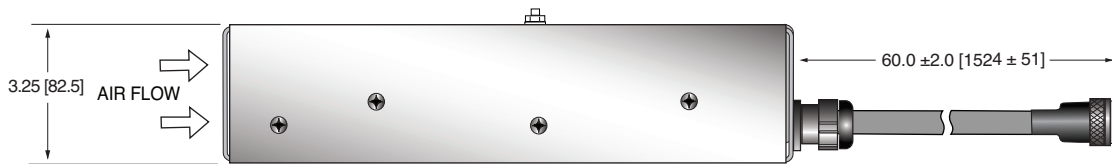

REAR VIEW

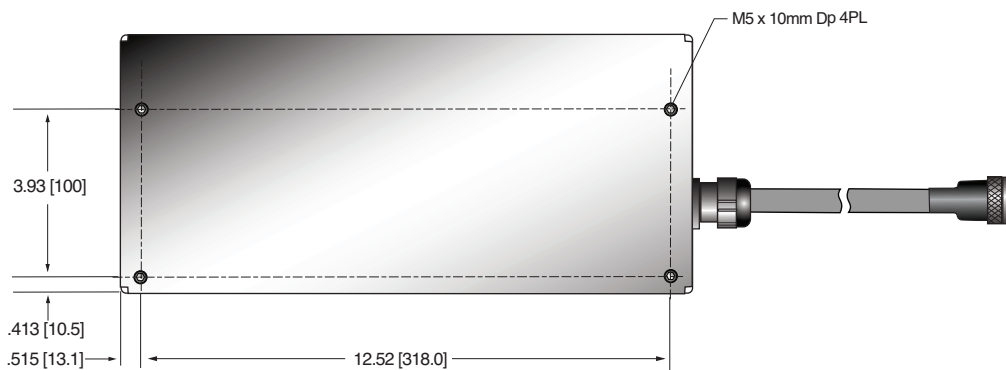

SIDE VIEW

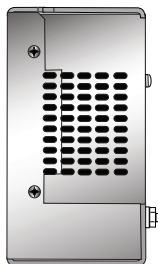

SIDE VIEW

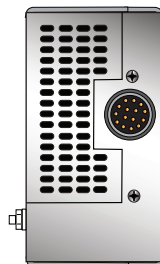

Standard
SE Side Exit shown

DIMENSIONS: in.[mm]

100W TANK TOP VIEW

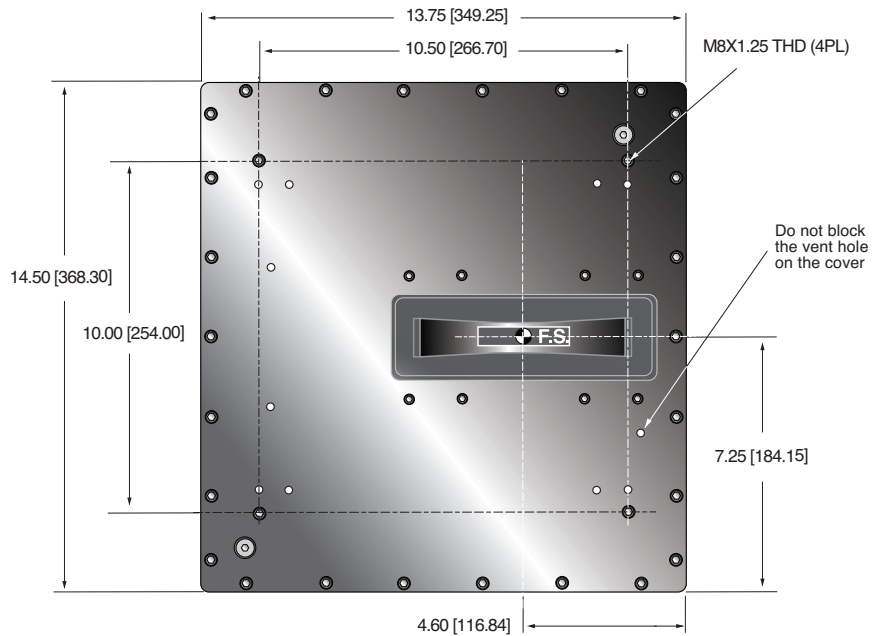

SIDE VIEW

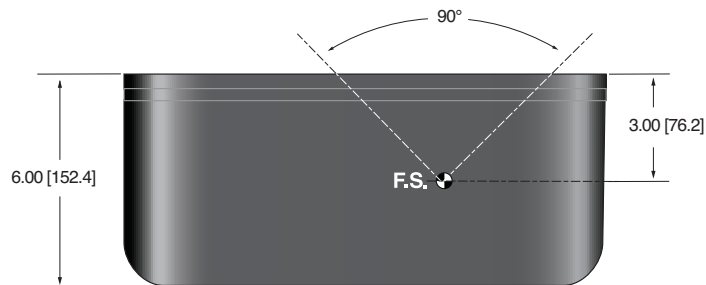

BACK VIEW

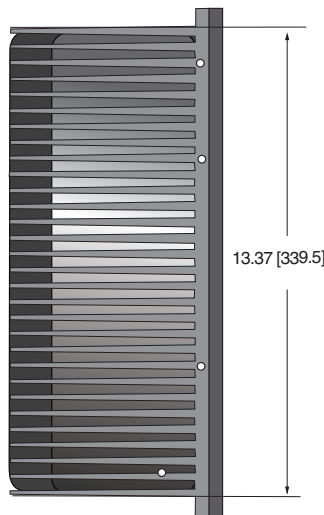

FRONT VIEW

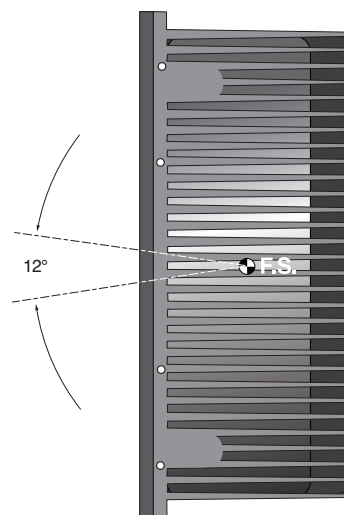

DIMENSIONS: in.[mm]

210W TANK TOP VIEW

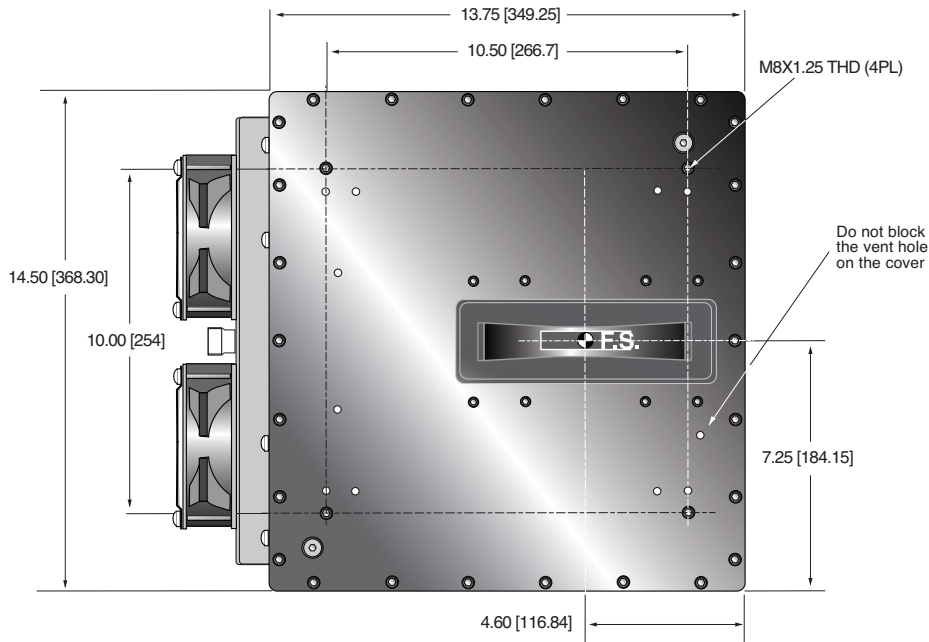

SIDE VIEW

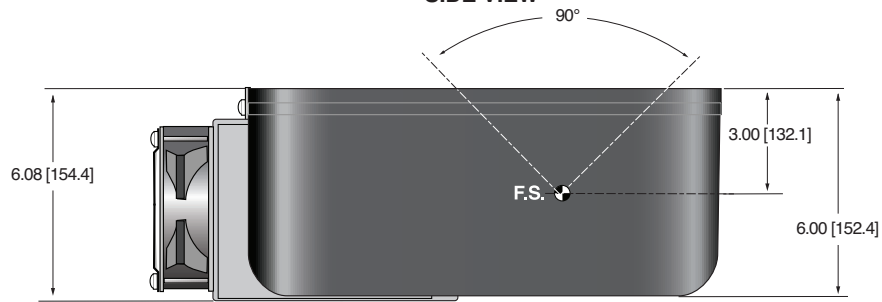

BACK VIEW



FRONT VIEW

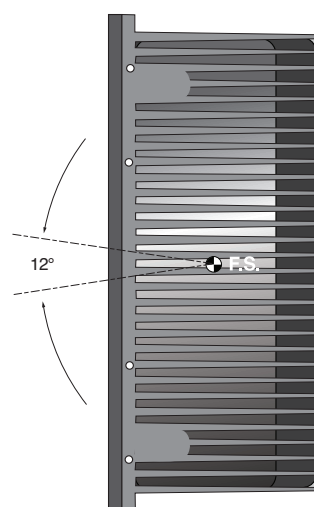

DIMENSIONS: in.[mm]

350/500W TANK
TOP VIEW

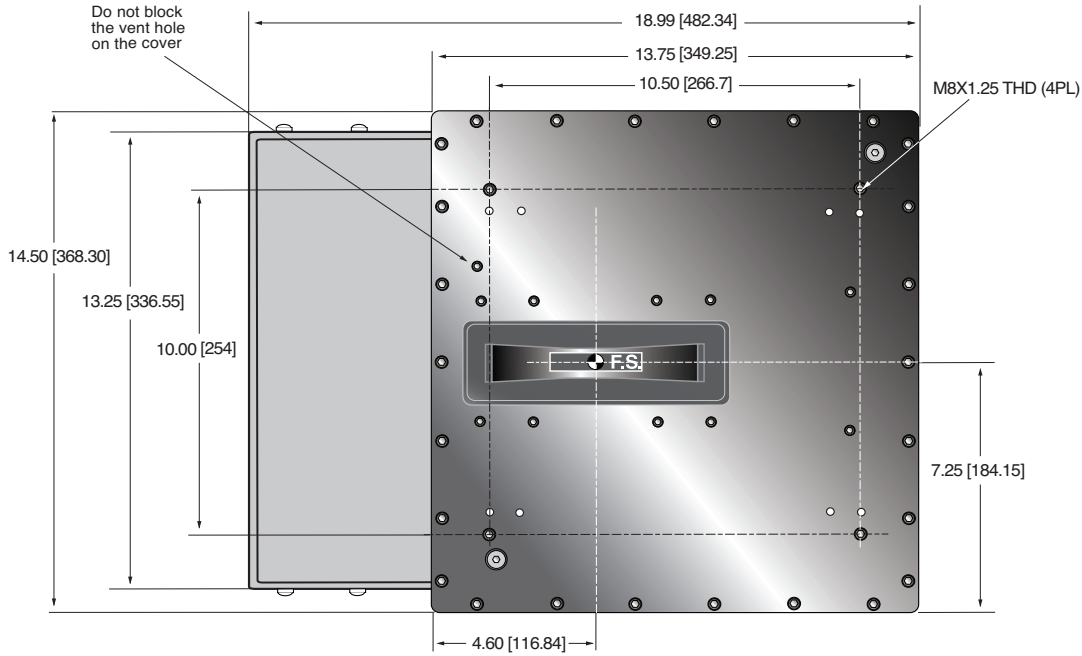

SIDE VIEW

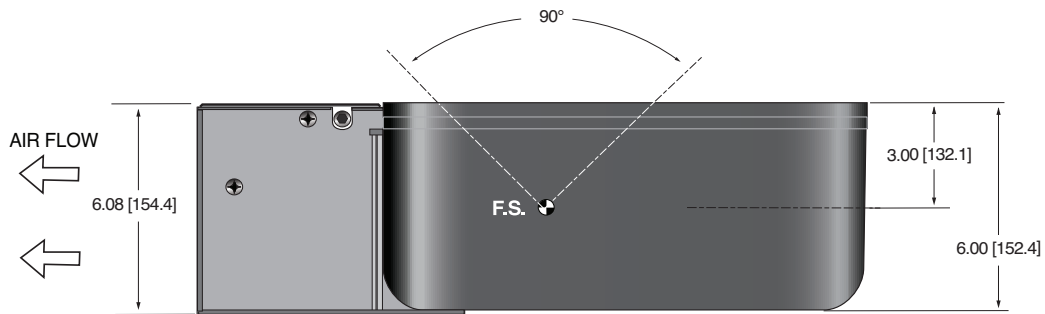

BACK VIEW

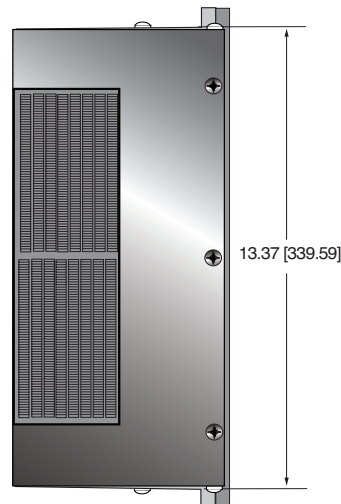

FRONT VIEW

